

# Energy Storage All In One

# User Manual

SUN-U/A Series

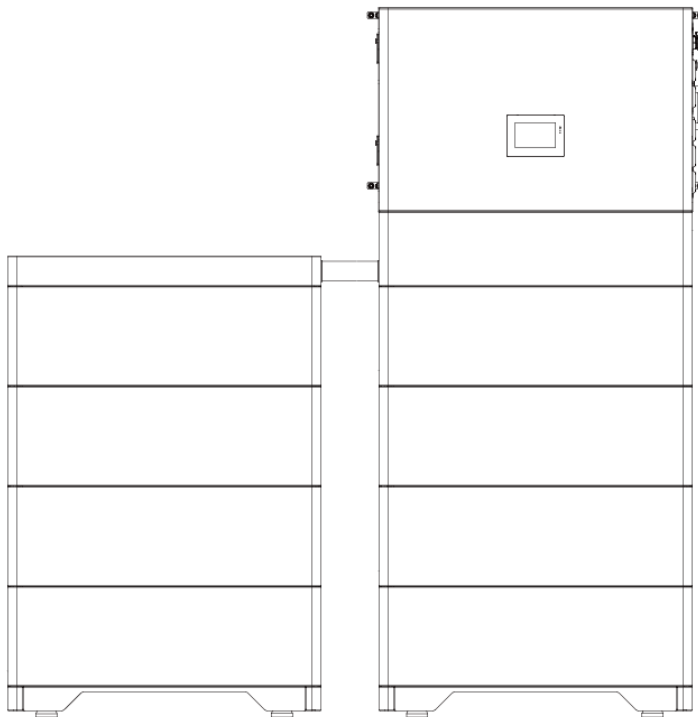

Document No: RD-SUN-U/A Series-Y-01

Version: V1.3     Date: March 13, 2026

**HUIZHOU ROYPOW TECHNOLOGY CO., LTD.**

✉ sales@roypow.com  
service@roypow.com  
marketing@roypow.com

📍 ROYPOW Industrial Park, No.16, Dongsheng South Road, Chenjiang Street,  
Zhongkai High-Tech District, Huizhou City, Guangdong Province, China

☎ +86 (0) 752 327 9099

🌐 www.roypow.com

## SUN-U/A Series

Type	Parameter
Product Name	Energy Storage All In One
Product Model	SUN10000/12000/15000S-U/A
Prepared by	QC. Yan
Examined by	JZ.Li / QW.Qiu / JL.Zhang



# Catalog

Preface.....	6
1. Safety.....	6
2. Product introduction .....	9
2.1 Overview.....	9
2.2 Product size.....	10
2.3 Product nameplate .....	10
2.4 Product description.....	11
2.5 Model definition.....	13
3. Installation.....	13
3.1 Packing list.....	13
3.2 Selecting the mounting location .....	14
3.2.1 Installation environment requirements .....	14
3.2.2 Installation angle requirements.....	15
3.2.3 Installation space requirements .....	15
3.3 Installation tool requirements .....	16
3.4 Installation .....	17
4. Electrical connections .....	23
4.1 Connect to protective earth .....	25
4.2 Connecting the DC input cable.....	25
4.3 Connecting the AC output cable.....	26
4.4 Communication connection.....	28
4.5 Connect the BMS communication line.....	29
4.6 Wiring Diagram Of All-In-One.....	30
4.7 AC coupling function and typical application diagram .....	31
4.8 Parallel function and wiring diagram.....	31
4.8.1 Split-phase parallel.....	31
4.8.2 Three units in parallel form a three-phase system.....	34
5. Inverter working mode .....	37
5.1 Self consume mode.....	37
5.2 Peak shift mode .....	38
5.3 BAT priority .....	38

5.4 Electricity sales mode .....	39
6. Startup/Shutdown the system .....	40
6.1 Check before power on .....	40
6.2 Startup the system .....	41
6.3 Shutdown the system .....	41
7. Commissioning .....	41
7.1 Inspection .....	41
7.2 System commissioning .....	41
7.2.1 LED indicators .....	42
7.2.2 Display parameter setting .....	42
7.3 Remote control instructions .....	45
7.4 Cycling capacity 72 hour reset .....	45
8. Maintenance .....	47
8.1 Routine battery maintenance .....	47
8.2 Inverter routine maintenance .....	47
8.3 Removing the inverter .....	47
9. Troubleshooting .....	48
10. Technical specifications .....	56

## Preface

### About this manual

This manual introduces the installation, connection, LCD screen use, debugging, and maintenance of energy storage equipment. Please read this manual and related documents carefully before using this product, and store them in a place where installation, operation, and maintenance personnel can access them at any time. The illustrations in this user manual are for reference only. This user manual is subject to change without prior notice. (Please refer to the actual object for details)

### Target group





Energy storage all in one must be installed by a licensed electrician who has obtained relevant qualifications.

### Scope

This manual is applicable to following inverters: SUN10000S-U, SUN12000S-U, SUN15000S-U.

### Safety instructions

The following safety instructions and general information are used within this user manual.

	<b>DANGER</b>	Indicates an imminently hazardous situation which, if not correctly followed, will result in serious injury or death.
	<b>WARNING</b>	Indicates a potentially hazardous situation which, if not correctly followed, will result in serious injury or death.
	<b>CAUTION</b>	Indicates a potentially hazardous situation which, if not correctly followed, could result in moderate or minor injury.
	<b>NOTICE</b>	Indicates a potentially hazardous situation which, if not correctly followed, could result in equipment failure to run, or property damage.
	<b>NOTE</b>	Calls attention to important information, best practices and tips: supplements additional safety instructions for better use of the ESS inverter to reduce waste resources.









## 1. Safety

Before using the energy storage all in one, please read all instructions and cautionary markings on the unit and manual. Put the instructions where you can find them easily.

The energy storage all in one strictly conforms to related safety rules in design and test. Local safety regulations shall be followed during installation, operation and maintenance. Incorrect operation may cause

injury or death to the operator or a third party and damage to the inverter and other properties belonging to the operator or a third party.

## Symbols Used

Safety Symbol	Description
	Danger of high voltage and electric shock! Only qualified personnel may perform work on the inverter.
	Danger of high voltage. Residual voltage in the inverter need 5 mins to discharge, wait 5 mins before operation.
	Danger of hot surface
	Watch out for danger
	Environmental Protection Use Period
	Refer to the operating instructions
	Product should not be disposed as household waste.
	Grounding terminal

## Safety Precaution

- Installation, maintenance and connection must be performed by qualified personnel, in compliance with local electrical standards, wiring rules and requirements of local power authorities and companies.
- It is forbidden to carry out installation, wiring and other operations with power on. Before installation, DC input and AC output of the inverter must be terminated at least 5 minutes before performing any installation or maintenance. For equipment that needs to be grounded, a protective ground wire must be installed first during installation. When dismantling the device, the protective earth must be removed last.
- The temperature of some parts of the inverter may exceed 140°F (60°C) during operation. To avoid being burnt.
- Ensure children are kept away from inverters.

- Don't open the front cover of the inverter. Apart from performing work at the wiring terminal (as instructed in this manual), touching or changing components without authorization may cause injury to people, damage to inverters and annulment of the warranty.
- Appropriate measures must be taken to prevent damage to the inverter from static electricity, as it may cause harm to electronic components. Failure to do so could result in damage to the inverter and voiding of its warranty.
- Ensure the output voltage of the proposed PV array is lower than the maximum rated input voltage of the inverter; otherwise the inverter may be damaged and the warranty annulled.
- When exposed to sunlight, the PV array generates a dangerously high DC voltage. Please follow instructions carefully to avoid any potential danger to life.
- PV modules should have an IEC61730 class A rating.
- If the equipment is used in a manner not specified by the manufacturer, the protection provided by the equipment may be impaired.
- Before maintenance, the inverter must be completely isolated. This involves switching off the PV switch, disconnecting the PV terminal, disconnecting the battery terminal, and disconnecting the AC terminal.
- Do Not insert or pull the AC and DC terminals when the inverter is running.
- Don't connect ESS inverter in the following ways:
  - BACKUP Port should not be connected to grid.
  - BACKUP Port should not be connected in parallel.
  - The single PV panel string should not be connected to two or more inverters.
- When a battery fault occurs, the temperature may higher than the burn threshold of touchable surface. Please do not touch it.
- Please do not short circuit battery terminals as it may cause fire.
- Before connecting or disconnecting battery terminals, please disconnect charging power, and make sure no-power at the power supply with multimeter.
- Please do not place any flammable items around the equipment. Please do not place the battery module in water or other liquids.
- Battery removal, alteration or sabotage is strictly prohibited, to prevent battery from leaking, overheat, on fire or explosion.
- Battery electrolyte warnings and guidelines:
  - If a battery leaks and electrolyte is spilled on your skin or clothing, wash the affected area with water immediately. If the battery leaks and the electrolyte enters the eyes, mouth, nose or other human body

parts, you should immediately rinse your eyes with plenty of water and seek medical treatment immediately, otherwise it will cause serious harm to the human body.

- Recycling and disposal:

Recycling and Disposal instructions: The product is made up of recyclable materials. Dismantling and destruction must take place in compliance with all local regulations concerning waste. At the end of its service life, the product must be transported to a processing center for electrical and electronic waste. The product contains lithium-ion (LFP) batteries that must be processed according to applicable local regulations concerning batteries.

The battery may be removed to comply with regulations and correct disposal.

- For indoor installation, smoke alarms must be installed in accordance with building and fire regulations.

## 2. Product introduction

### 2.1 Overview

The energy storage integrated machine converts the DC power generated by the photovoltaic string into AC power, and sends the power to the grid. At the same time, it can also store the photovoltaic power in the battery and then supply power to the load.

Inverters can be used to optimize their own consumption, stored in batteries for future use or fed into the public grid. The working mode depends on the photovoltaic energy source and the user's preference. It can use energy generated by batteries and inverters (generated by photovoltaics) to provide emergency power in the event of a grid loss.

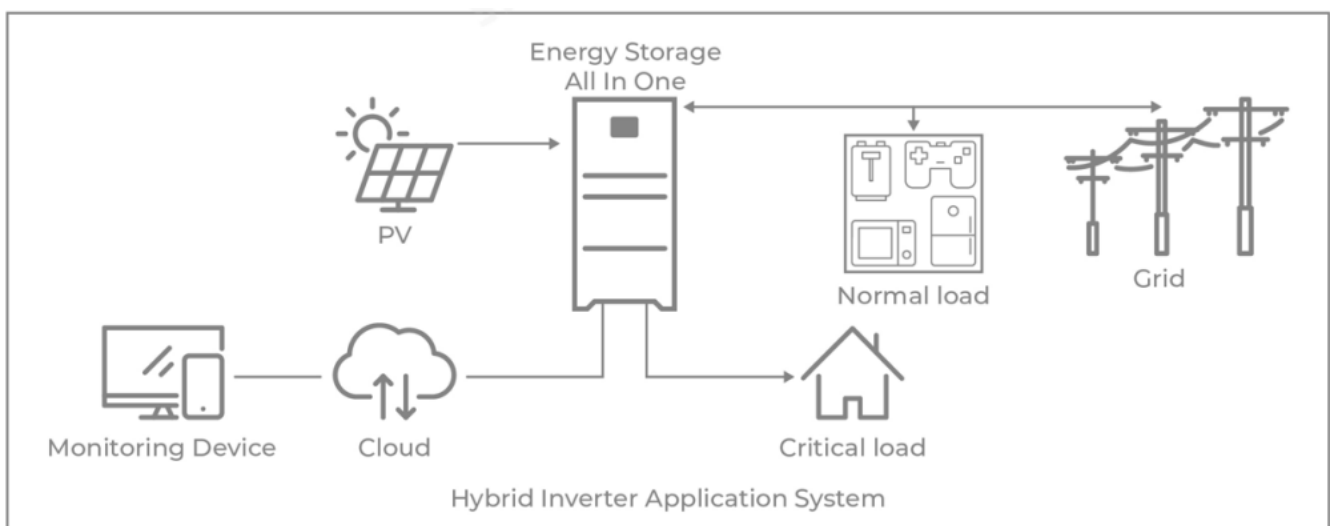

## 2.2 Product size

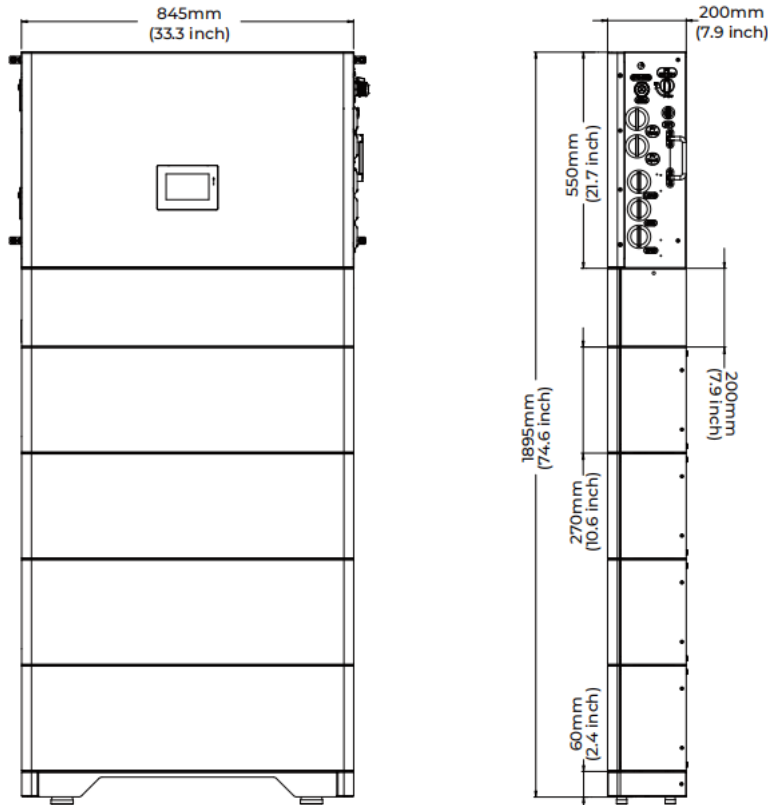

## 2.3 Product nameplate

**Rechargeable Li-ion Battery System**

Max. charge current: 50A  
Max. discharge current: 75A

Rated voltage range/ Nominal voltage:  
 89.6-113.6V d.c./102.4V d.c.  
 134.4-170.4V d.c./153.6V d.c.  
 179.2-227.2V d.c./204.8V d.c.  
 224-284V d.c./256V d.c.  
 268.8-340.8V d.c./307.2V d.c.  
 313.6-397.6V d.c./358.4V d.c.  
 358.4-454.4V d.c./409.6V d.c.

Rated capacity: 100Ah  
Ambient temperature: Charge: 32-131°F Discharge: -4-131°F  
IP rating: IP 65

S/N: RBmax5.1H  
23041100001

System Model	Rated energy	Usable energy
<input type="checkbox"/> 2*RBmax5.1H	<input type="checkbox"/> 10.24kWh	<input type="checkbox"/> 9.58kWh
<input type="checkbox"/> IFpp/51/161/119/[(16S)2S]M/-20+50/95	<input type="checkbox"/> 15.36kWh	<input type="checkbox"/> 14.37kWh
<input type="checkbox"/> 3*RBmax5.1H	<input type="checkbox"/> 20.48kWh	<input type="checkbox"/> 19.16kWh
<input type="checkbox"/> IFpp/51/161/119/[(16S)3S]M/-20+50/95	<input type="checkbox"/> 25.6kWh	<input type="checkbox"/> 23.95kWh
<input type="checkbox"/> 4*RBmax5.1H	<input type="checkbox"/> 30.72kWh	<input type="checkbox"/> 28.74kWh
<input type="checkbox"/> IFpp/51/161/119/[(16S)4S]M/-20+50/95	<input type="checkbox"/> 35.84kWh	<input type="checkbox"/> 33.53kWh
<input type="checkbox"/> 5*RBmax5.1H	<input type="checkbox"/> 40.96kWh	<input type="checkbox"/> 38.32kWh
<input type="checkbox"/> IFpp/51/161/119/[(16S)5S]M/-20+50/95		
<input type="checkbox"/> 6*RBmax5.1H		
<input type="checkbox"/> IFpp/51/161/119/[(16S)6S]M/-20+50/95		
<input type="checkbox"/> 7*RBmax5.1H		
<input type="checkbox"/> IFpp/51/161/119/[(16S)7S]M/-20+50/95		
<input type="checkbox"/> 8*RBmax5.1H		
<input type="checkbox"/> IFpp/51/161/119/[(16S)8S]M/-20+50/95		

Max. short circuit current: 2kA, 10ms

Made in China  
Manufacturer: Huizhou RoyPow Technology Co., Ltd.

**AC energy storage system**

Suitable for Use in Residential Non-Habitable Spaces

System Model:  SUNR0005-U/A  SUNI2005-U/A  
 SUNS0005-U/A

Consist of:  SUNR0005-U  SUNI2005-U  
 SUNS0005-U

Inverter Model:  SUNI2005-U

Battery Model:  2\*RBmax5.1H  3\*RBmax5.1H  
 4\*RBmax5.1H  5\*RBmax5.1H  
 6\*RBmax5.1H  7\*RBmax5.1H  
 8\*RBmax5.1H

DC PV Input  
Max PV Input:  14.4kW  20kW  24kW  
Mppt Input Volt: 100-560V  
Max Input Current:  15.5A<sup>4</sup>  27A<sup>4</sup>

Input SCCB: 40A  
Grid  
Rated Power (to grid):  10kVA  20kVA  15kVA  
Max AC Current (to grid):  41.6A  30A  62.5A  
Rated Power (from grid): 20kVA  
Max AC Current (from grid): 83.3A  
Grid Voltage: 120/240V  
Grid Frequency: 60Hz  
Power Factor Range: -0.8~0.8  
Max. overcurrent protection (amps) Branch Circuit breaker: 100A, 3P

Voltage Range: 211.2 Vac/264 Vac  
Output available fault current: 191 Arms/ 1 cycle, 63Apeak/ 3 ms

Back-up Output  
Max AC Apparent Output Power: 19kVA  
Max AC Apparent Output Current: 79.2A  
Back-up Voltage: 120/240V  
Back-up Frequency: 60Hz  
Voltage Range: 105.6-132Vac  
Max. Overcurrent Protection: 100A, 3P

DC Battery  
Battery Voltage Range: 83.2V-467.2V  
Max. charging Current: 50A  
Max. discharging Current: 75A  
Rated energy  
 10.24kWh  15.36kWh  20.48kWh  25.6kWh  
 30.72kWh  35.84kWh  40.96kWh

Usable energy  
 9.58kWh  14.37kWh  19.16kWh  23.95kWh  
 28.74kWh  33.53kWh  38.32kWh

GEN  
Nominal input voltage: 240Vac(L1L2)  
Nominal frequency: 60Hz  
Max. input current: 79.2Aac  
Max. input power: 19kW  
Max. Overcurrent Protection: 100A, 2P  
Voltage Range: 211.2-264Vac

System  
Inverter Enclosure Type: Type 4X  
Battery Enclosure Type: IP65  
Operating Temperature: +32°F~+132°F  
no derating below 113°F

S/N: SUN10005-U/A 24052100001

Huizhou RoyPow Technology Co., Ltd.  
Made in China

Support Email: service@roypowusa.com  
Customer Hotline: +1-512-688-5555  
Company Address: 16233 Arrow Hwy Bldg B, Irwindale, CA 91706, USA

## 2.4 Product description

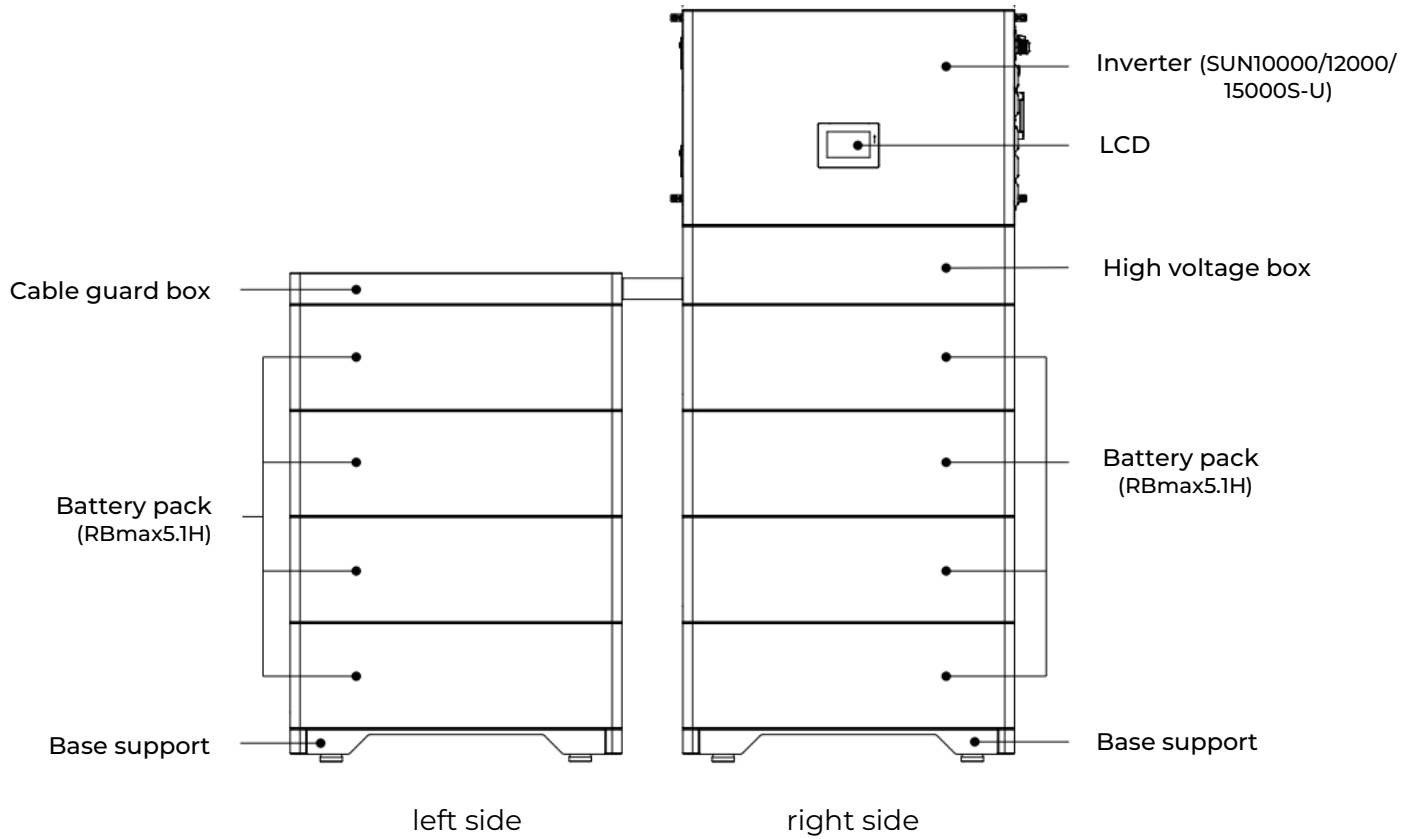

### Inverter:

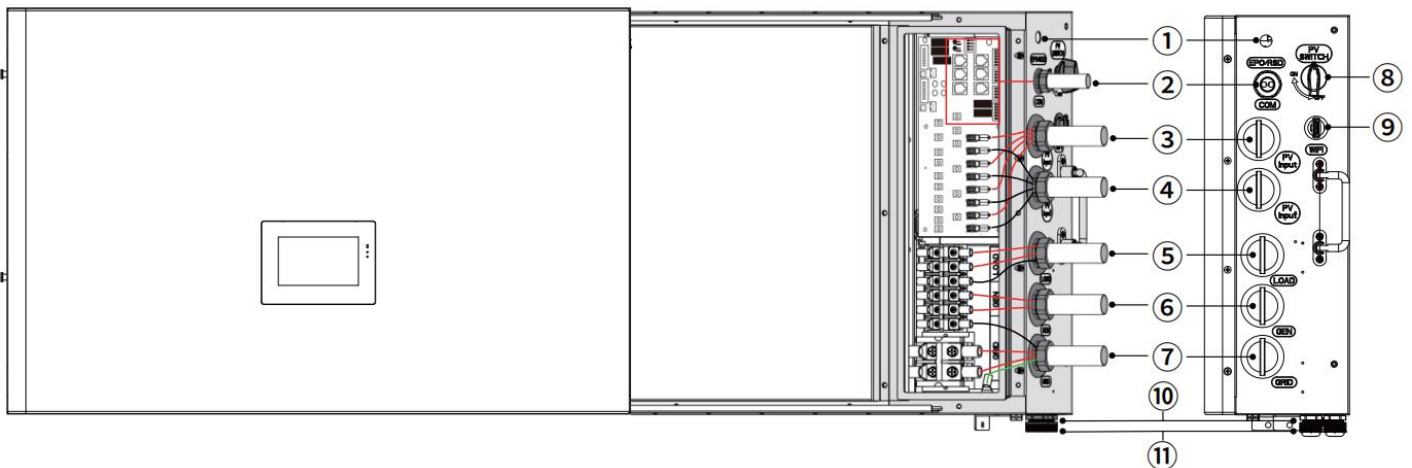

① EPO/RSD switch	② Communication Port	③ PV Cable Input Port	④ PV Cable Input Port
⑤ Load Port	⑥ Generator Port	⑦ Grid Port	⑧ PV DC Input Switch
⑨ WIFI Port	⑩ Battery Port	⑪ BMS Port	

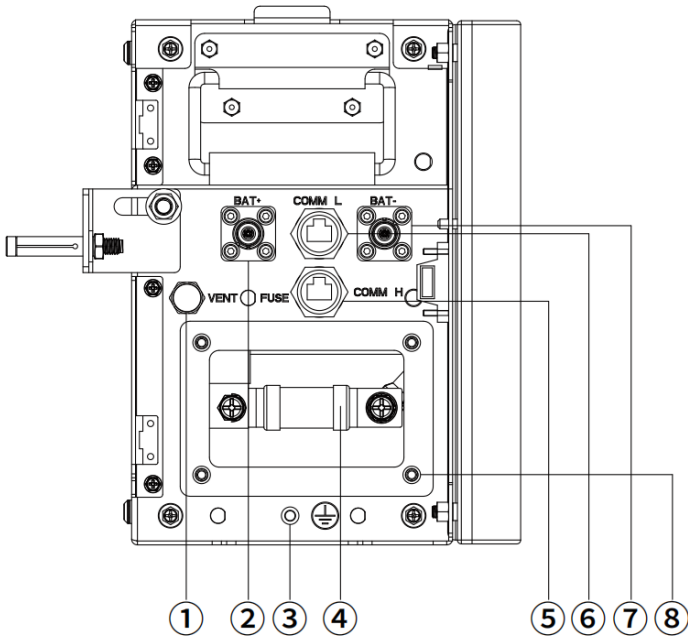
**Battery:**

① Vent	② BAT+ (battery positive pole)
③ Grounding	④ Fuse
⑤ Daisy Chain OUT	⑥ Daisy Chain IN
⑦ BAT- (battery negative pole)	
⑧ Side cover fixing screws (the fuse can be replaced after disassembly)	

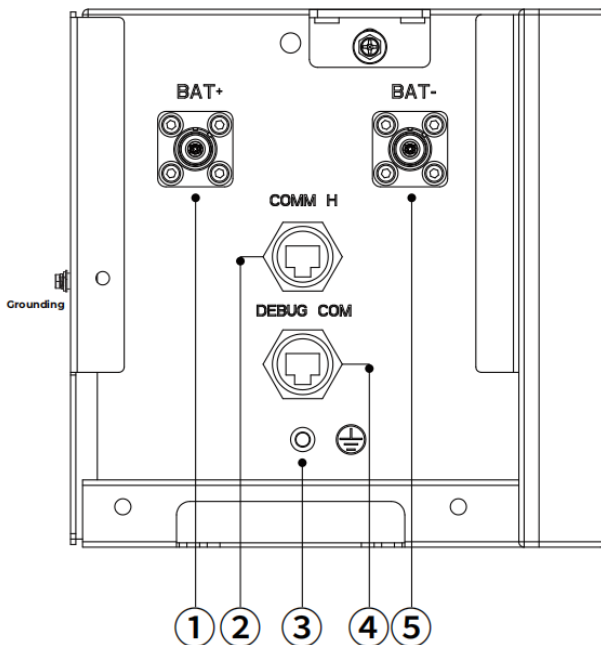
**High Voltage Box:**

① BAT+ (battery positive pole)	② Daisy Chain OUT
③ Grounding	④ Debug
⑤ BAT- (battery negative pole)	

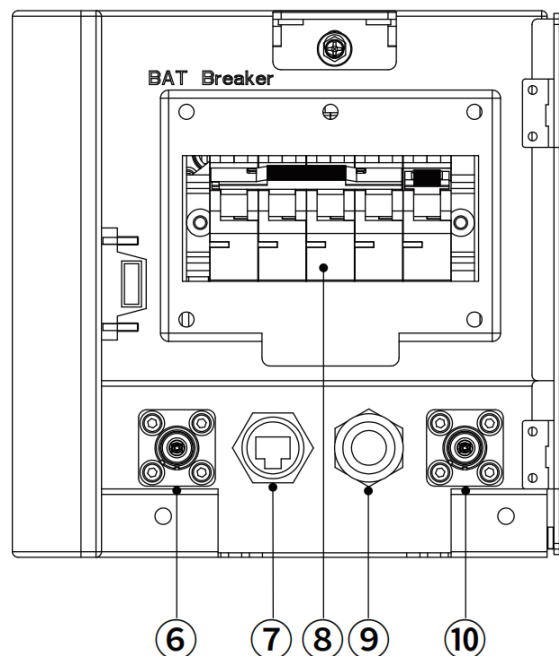

⑥ P+(inverter positive pole)	⑦ CAN
⑧ Breaker	⑨ ON/OFF
⑩ P-(inverter negative pole)	

## 2.5 Model definition

The letters in the product model have the specific information.(Take SUN 15000S-U/A as example.)

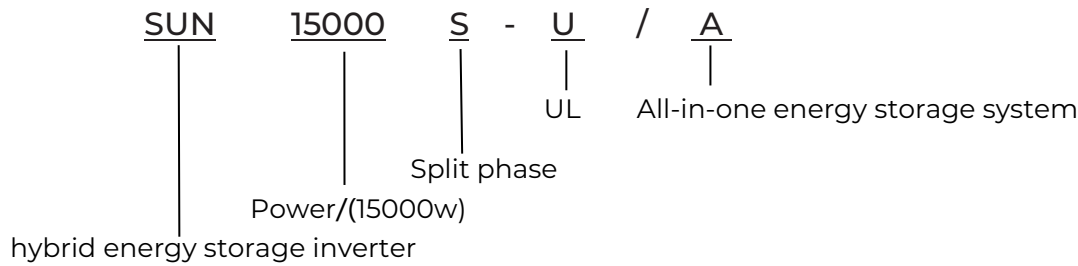

## 3. Installation

### 3.1 Packing list

After unpacking, please carefully check the following packing list for damage or missing items. In the event of any damage or missing parts, please contact the supplier for assistance.





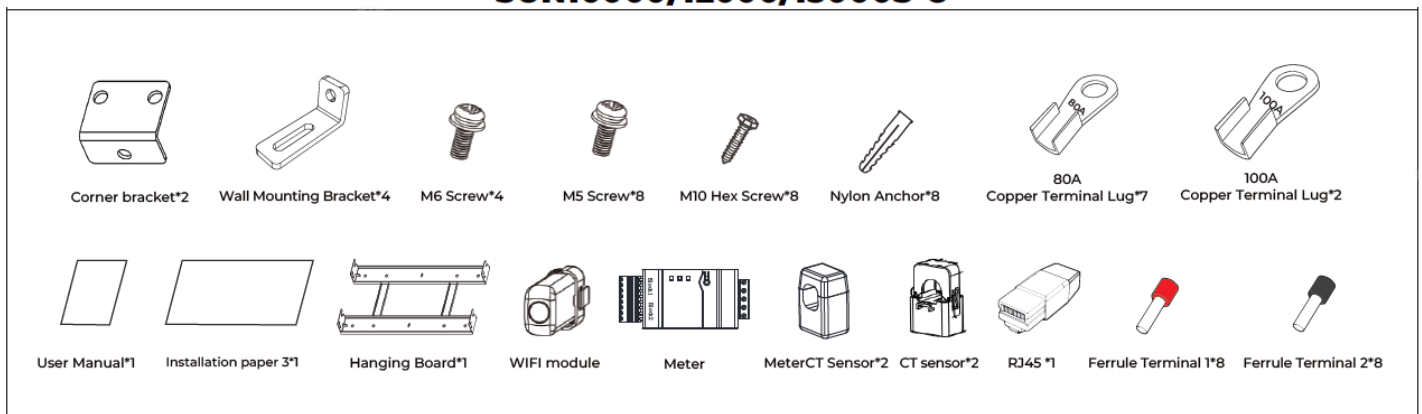



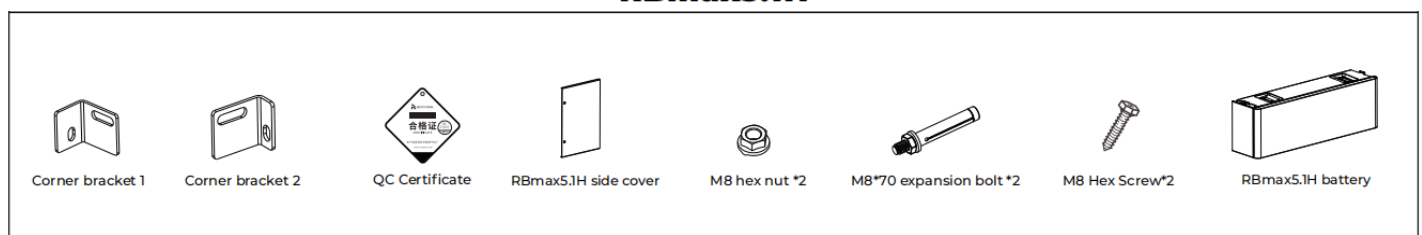



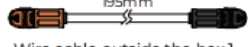





CONFIGURATION LIST			
Model	Battery box	Main control box	Accessories box
2*RBmax5.1H	RBmax5.1H (2pcs)	2*RBmax5.1H Main control box (1pcs)	/
3*RBmax5.1H	RBmax5.1H (3pcs)	3*RBmax5.1H Main control box (1pcs)	/
4*RBmax5.1H	RBmax5.1H (4pcs)	4*RBmax5.1H Main control box (1pcs)	/
5*RBmax5.1H	RBmax5.1H (5pcs)	5*RBmax5.1H Main control box (1pcs)	5*RBmax5.1H Accessories (1pcs)
6*RBmax5.1H	RBmax5.1H (6pcs)	6*RBmax5.1H Main control box (1pcs)	6*RBmax5.1H Accessories (1pcs)
7*RBmax5.1H	RBmax5.1H (7pcs)	7*RBmax5.1H Main control box (1pcs)	7*RBmax5.1H Accessories (1pcs)
8*RBmax5.1H	RBmax5.1H (8pcs)	8*RBmax5.1H Main control box (1pcs)	8*RBmax5.1H Accessories (1pcs)

### SUN10000/12000/15000S-U

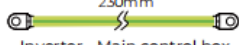

### RBmax5.1H

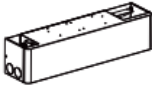

Main control box+Accessories box													
①  RBmax 5.1H top cover			②  RBmax 5.1H base			⑤  Wire cable outside the box 1			⑧  Wire cable outside the box 2				
③-1  M8*70 expansion bolt		③-2  M6*12 hex Phillips combination screw		③-3  Corner bracket 3		③-4  Corner bracket 4		⑥  8 core connecting cable 3			Wire cable outside the box 4		
④  Warranty card			 Installation paper 1			 Installation paper 2			⑦  8 core connecting cable			⑧  Inverter - Main control box Ground wire	
 QC Certificate			 RBmax 5.1H side cover			 M5*10 flat head bolts *25			 High voltage box			⑧  8 core connecting cable 4	
ITEM	①	②	③-1	③-2	③-3	③-4	④	⑤	⑥	⑦	⑧		
4*RBmax5.1H	X	1	10	40	18	2	1	3	4	X	1		
6*RBmax5.1H	1	2	16	64	28	4	1	4	5	1	1		
8*RBmax5.1H	1	2	20	76	32	4	1	6	7	1	1		

## 3.2 Selecting the mounting location

### 3.2.1 Installation environment requirements

- The mounting location Should be located in a Protected area since the enclosure and heat sinks are extremely hot during operation.
- Do not install the product in areas containing highly flammable materials or gases.
- To ensure optimum operation and long service life, the ambient temperature must be below 122°F (50°C).
- The product must be mounted in a well ventilated environment to ensure good heat dissipation.
- To ensure long service life, the product must not be exposed to direct solar irradiation, rain, or snow. It is recommended that the product be mounted in a sheltered place.
- The carrier where the product is mounted must be fire-proof. Do not mount the product on flammable building materials.
- Do not install the product in a rest area since it will cause noise during operation.
- The installation height should be reasonable to make sure it is easy to operate and view the display.
- Product label and warning symbols should be clear to read after installation.
- Choose a wall capable of supporting the full weight of product, with one of the following characteristics:
  - Wood studs at regular intervals

- Plywood sheeting of sufficient thickness
- Solid concrete or masonry
- Metal studs of sufficient gauge

- Concrete or Masonry:

Minimum strength must be 2500 PSI (concrete) or 1500 PSI (masonry).

Use at least four (one in each corner) 1/4-inch fasteners with washers, of sufficient length for at least 1.5 in (38 mm) embedment into the material. Ensure that all fasteners are at least 1.5 in (38 mm) away from the edges of masonry blocks or bricks.

- Indoor installations are recommended in attached or detached garages, sheds, and locations more than 152.4 cm (5 feet) from the residence and not in bedrooms and living spaces of the residence, including bathrooms, toilets, closets, halls, and storage spaces.

- Do not use it near the seaside or in earthquake zones.

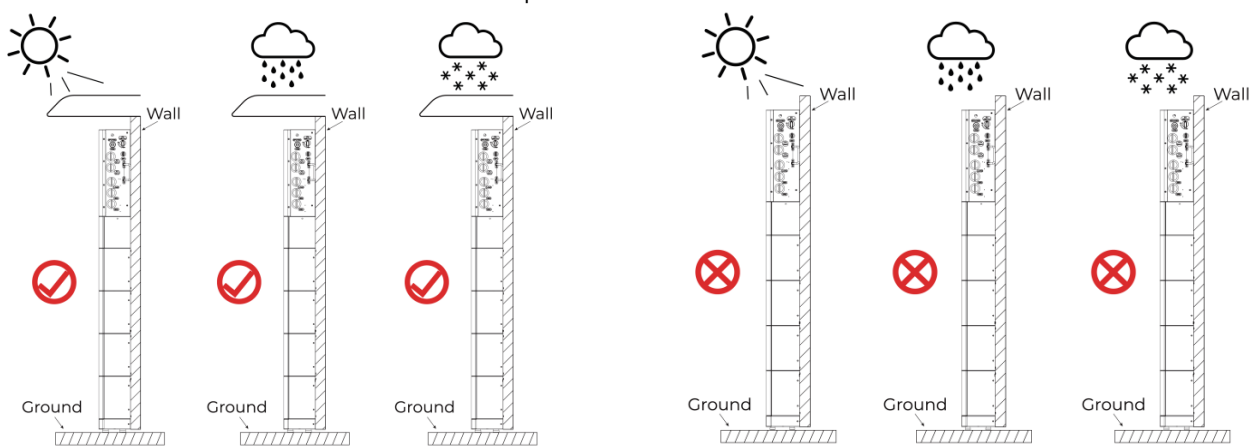

### 3.2.2 Installation angle requirements

Recommended inverter installation angle: vertical.  
Do not turn the inverter upside down, or install it horizontally.

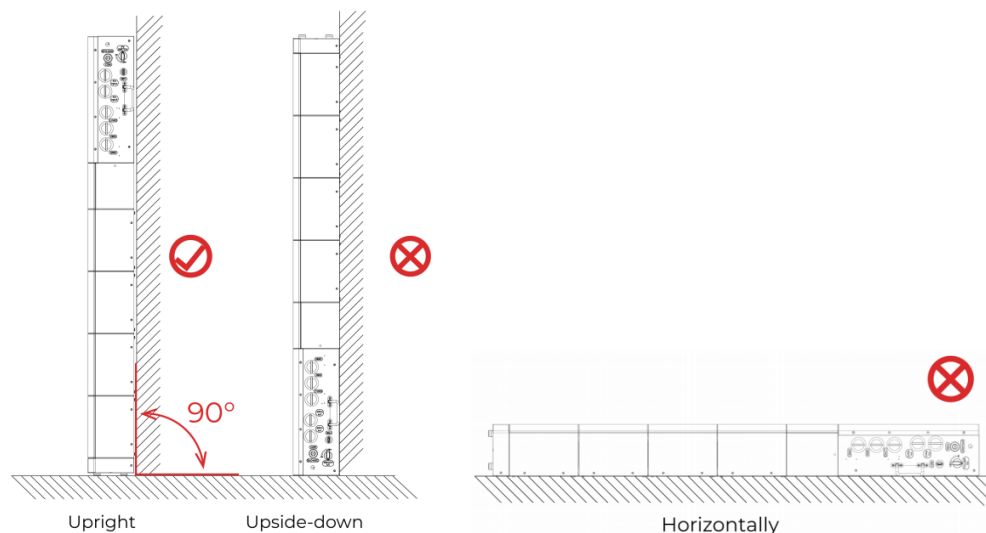

### 3.2.3 Installation space requirements





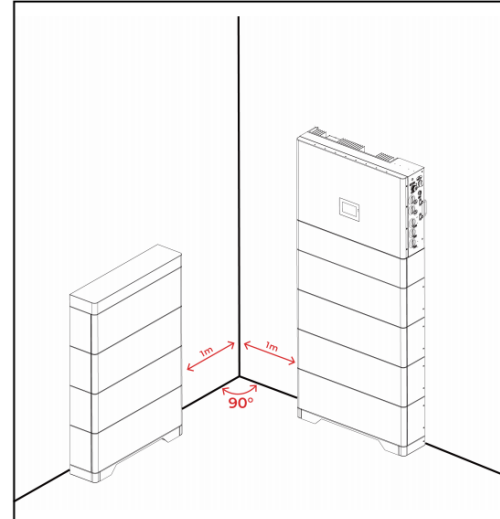
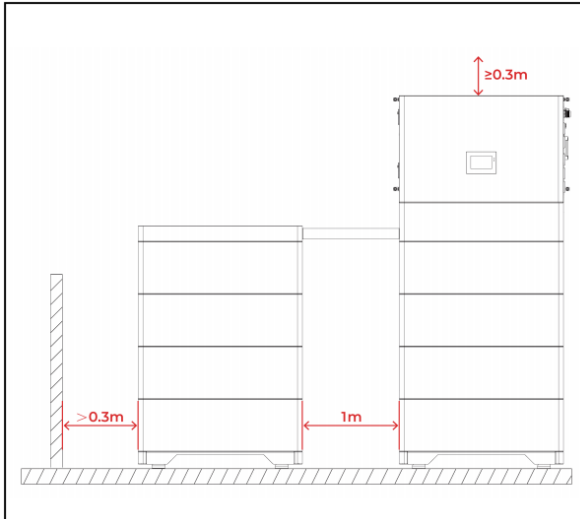





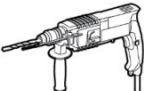

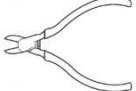
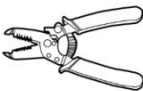
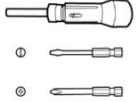





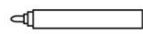

To ensure normal and easy to operate of the Energy Storage All In One, there are requirements on available spaces of the Energy Storage All In One, eg. to keep enough clearance. Refer to the following figures.

**RoyPow confidential** / All rights reserved: no part of these pages may be used for any purpose other than for the purpose expressly permitted by RoyPow. Reproduction, modification, storage in a retrieval system or retransmission, in any form or by any means, electronic, mechanical or otherwise is strictly prohibited.



### 3.3 Installation tool requirements

The following tools are recommended when installing the equipment. Use other auxiliary tools if necessary.

				
Hammer drill	Torque socket wrench	Torque wrench	Diagonal plier	Wire stripper
				
Torque screwdriver	Rubber mallet	Utility knife	Cable cutter	Heat shrink tubing
				
Heat gun	Cable tie	Vacuum cleaner	Multimeter (DC voltage measurement range $\geq 600$ VDC)	Marker
				
Measuring tape	Level	Stud finder	Hex key (M6)	Safety shoes
				
Safety gloves	Safety goggles	Anti-dust respirator	Safety ladder	Safety Helmet Hat

### 3.4 Installation

**\* Install the base, battery pack, high voltage box, and inverter on the right side.**

Notice: When drilling, make sure that the drilling position avoids water pipes and cables on the ground and walls to avoid danger; when drilling, please wear goggles and a dust mask to prevent dust from being inhaled into the respiratory tract or falling into the eyes;

#### 1. Install the base

Place the **installation paper 1** on a flat surface, close to the wall; mark two installation holes with a marker; place the base on the ground, aligning the installation holes on both sides.

Place a level on the base to check whether the base is level (rotate and adjust the four foot pads at the bottom of the base).

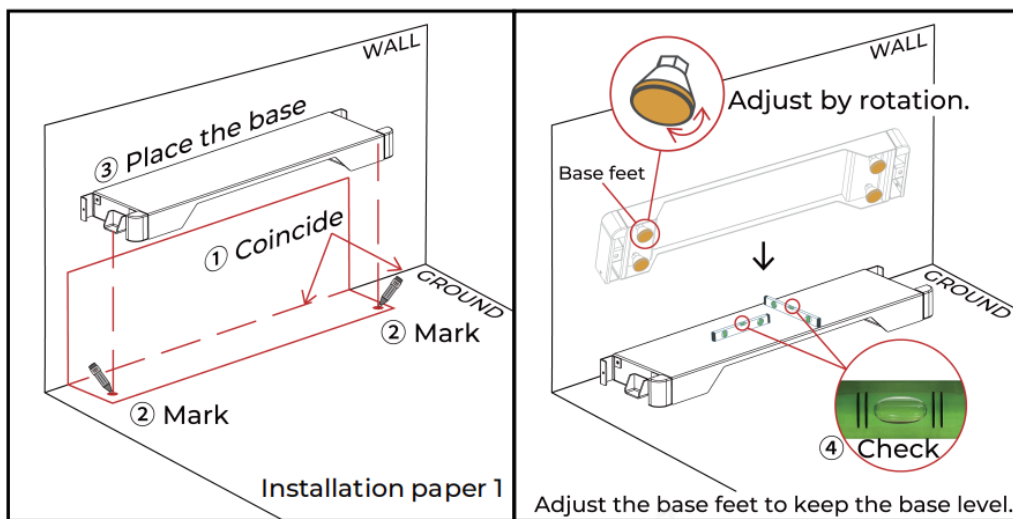

**When the base does not need the feet to remain level, you can choose a fixed base.**

- ① Use an electric drill to drill holes at the marked locations (hole diameter 10mm, hole depth 50-55mm);
- ② Place the M8\*70 expansion bolt kit into the hole;
- ③ Tighten the nut with a torque of 15 N.m;
- ④ Loosen the nut in the opposite direction and remove the nut and gasket;
- ⑤ After placing the base, tighten the nut.

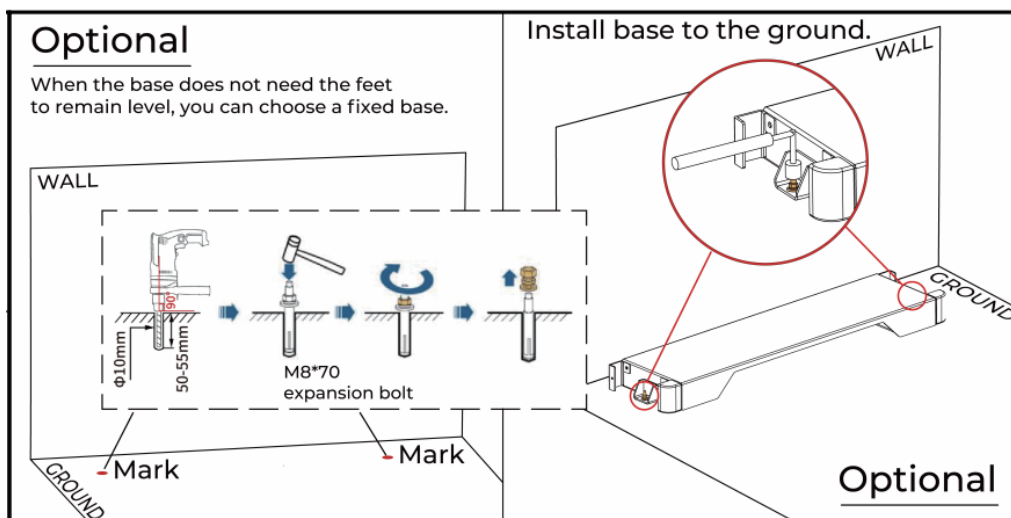

## 2. Install the battery pack

- ① Place the installation paper 1 on the base and fit it against the wall; mark two installation holes on the wall;
- ② Use an electric drill to drill holes at the marked locations (hole diameter 10mm, hole depth 50-55mm);
- ③ Place the M8\*70 expansion bolt kit into the hole;
- ④ Tighten the nut with a torque of 15 N.m;
- ⑤ Loosen the nut in the opposite direction and remove the nut and gasket.

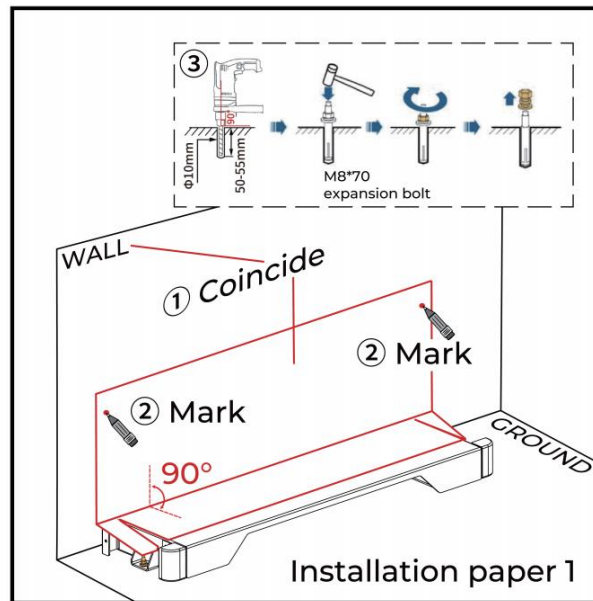

- ⑥ Place the battery pack on the base;  
Left side of the battery pack: Use M8 hex nut (Torque: 25-30 N.m) to lock the fixed connection bracket 1 to the bolts between the battery pack and the wall. (Tighten the nut with a wrench)
- ⑦ Right side of the battery pack: The right fixed connection bracket 2 is the same.

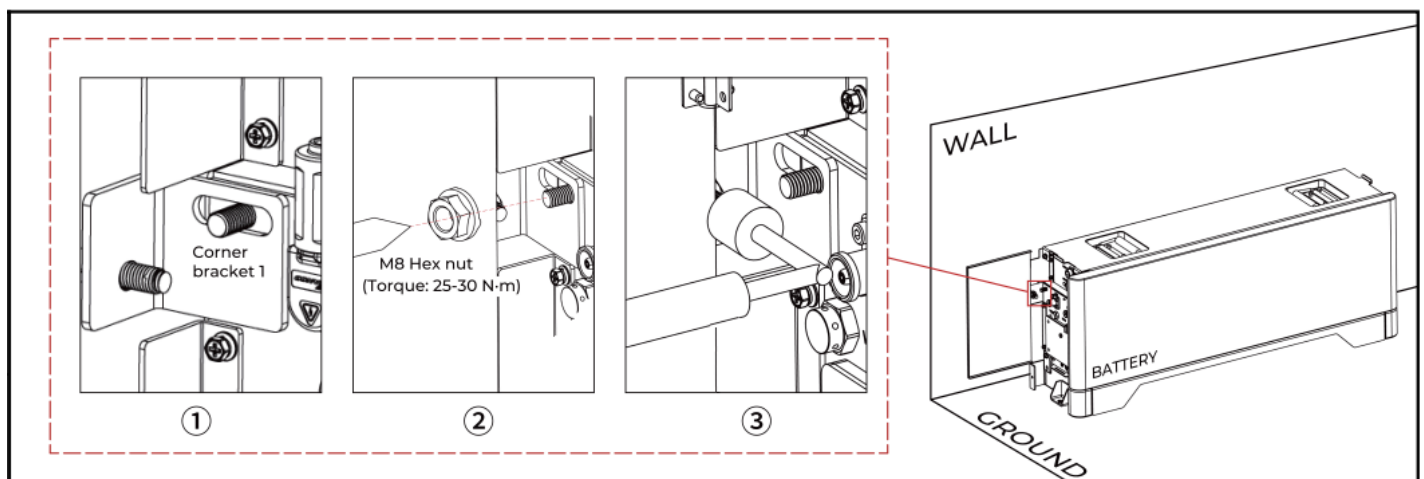

⑧ Use fixing screws to lock the corner bracket3/corner bracket4 on the left and right sides of the base and the battery. (M6\*12 hex phillips (Torque: 8-15 N.m))

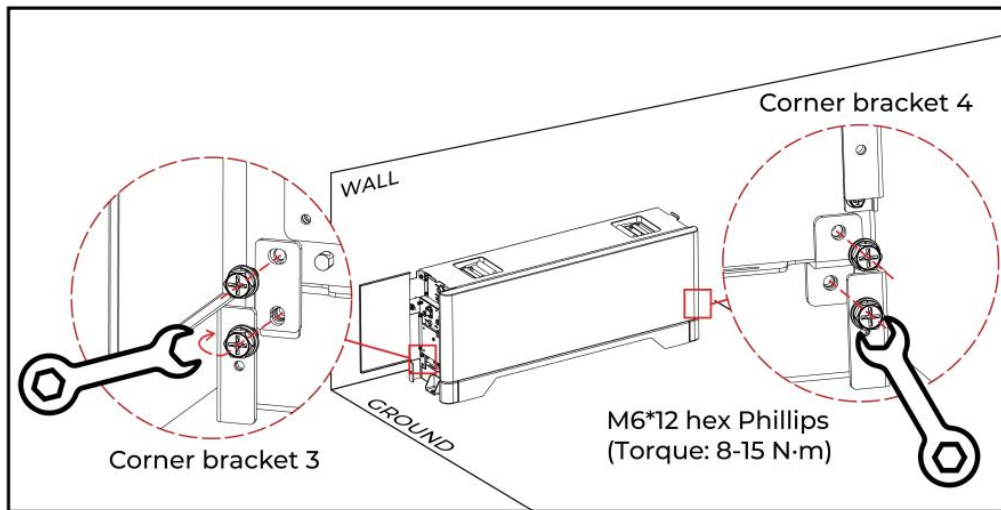

**3. Repeat steps 2 (if multiple battery packs are installed in a single row on the right)**

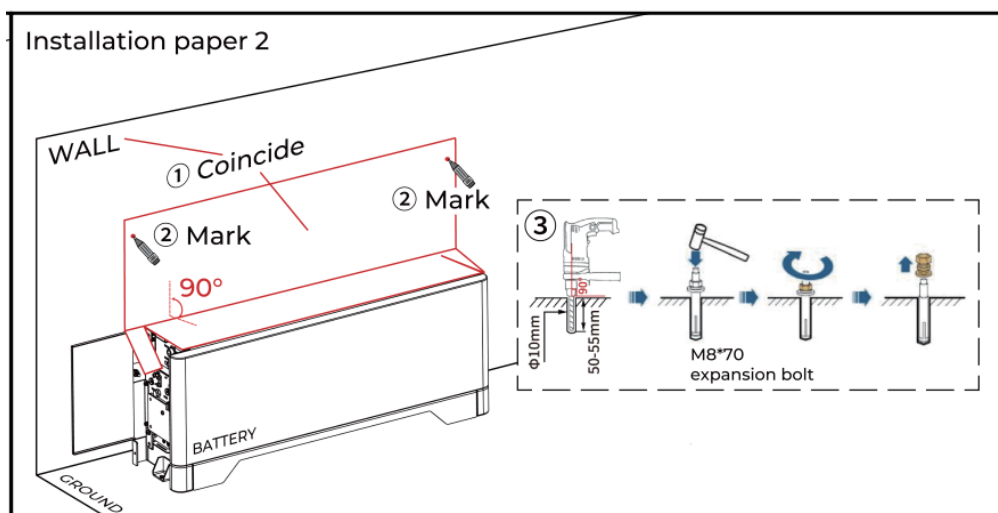

#### 4. Install the high voltage box

The high-voltage box is placed on the battery pack, and the connecting brackets are locked on the left and right sides with fixing screws. (corner bracket3, M6\*12 hex phillips (Torque: 8-15 N.m))

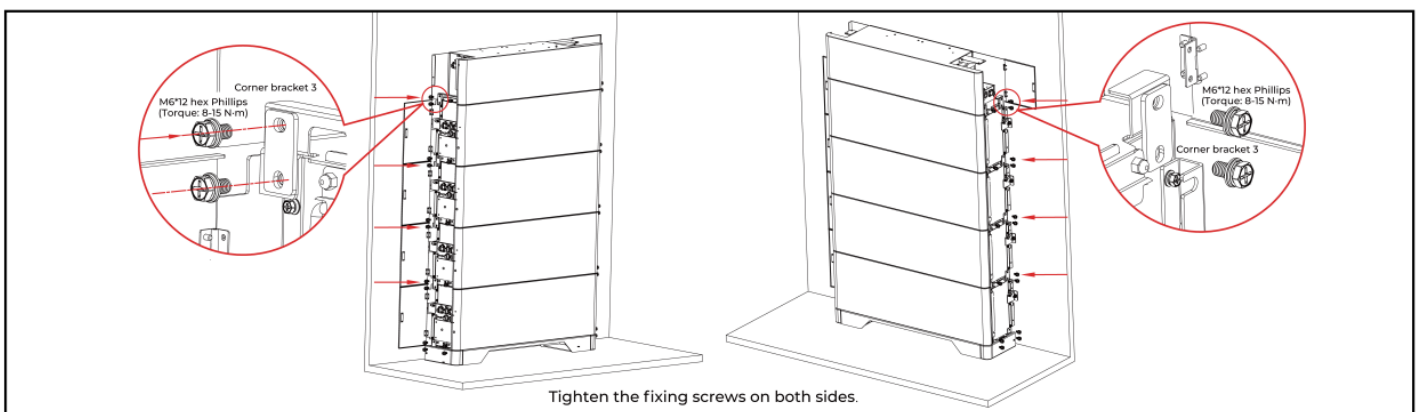

### 5. Install the inverter

- ① Place the **installation paper 3** on the top of the high-voltage box and fit it against the wall; mark eight installation holes on the wall;
- ② Use an electric drill to drill holes at the marked locations (hole diameter 10mm, hole depth 65mm);
- ③ Secure the back-panel bracket to the wall with 8 self-tapping screws;
- ④ Mount the inverter on the back panel.

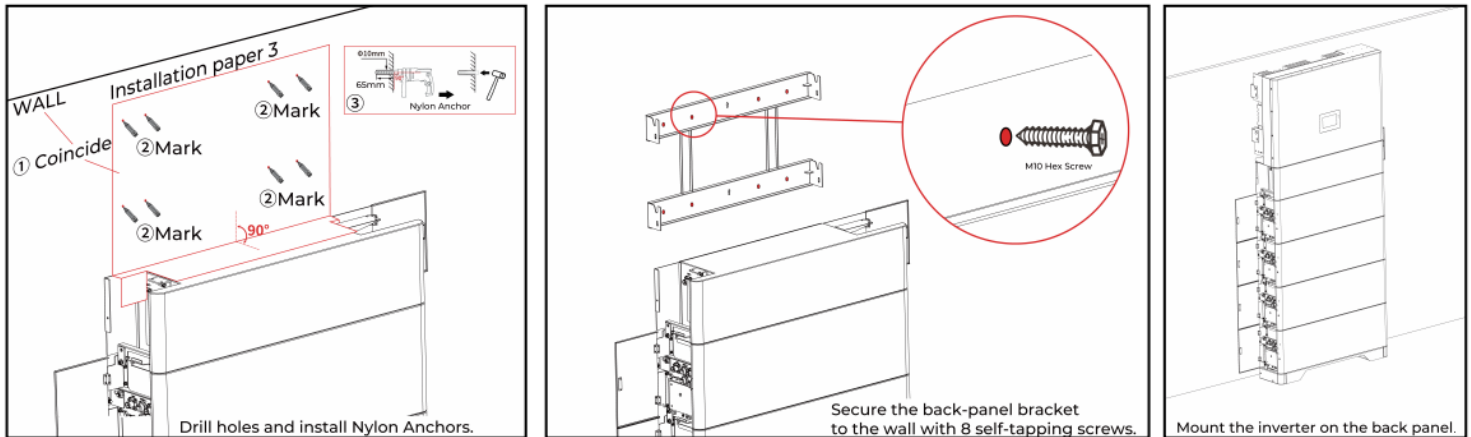

- ⑤ Fix the high voltage box and the inside of the right side of the inverter with screws;  
Lock the connecting bracket on the left side of the high voltage box and inverter with screws.  
(M6\*12 hex phillips (Torque: 8-15 N.m))

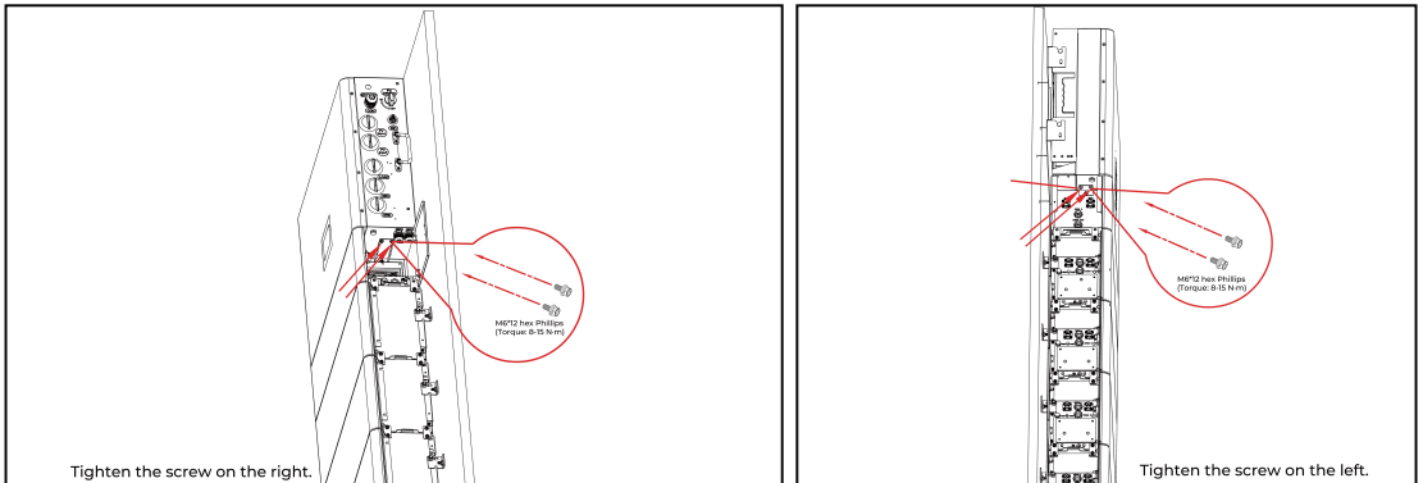

#### Notice:

Make sure that the inverter is installed firmly to prevent people from being injured;

The DC switch lock is prepared by the user, the aperture is:  $\phi 5mm$ , please choose a suitable DC switch lock, otherwise it may cause failure to install;

\* Mounting base, battery pack, and cable protection box on the left.

**6. Install the base and multiple battery packs: repeat steps 1-3**

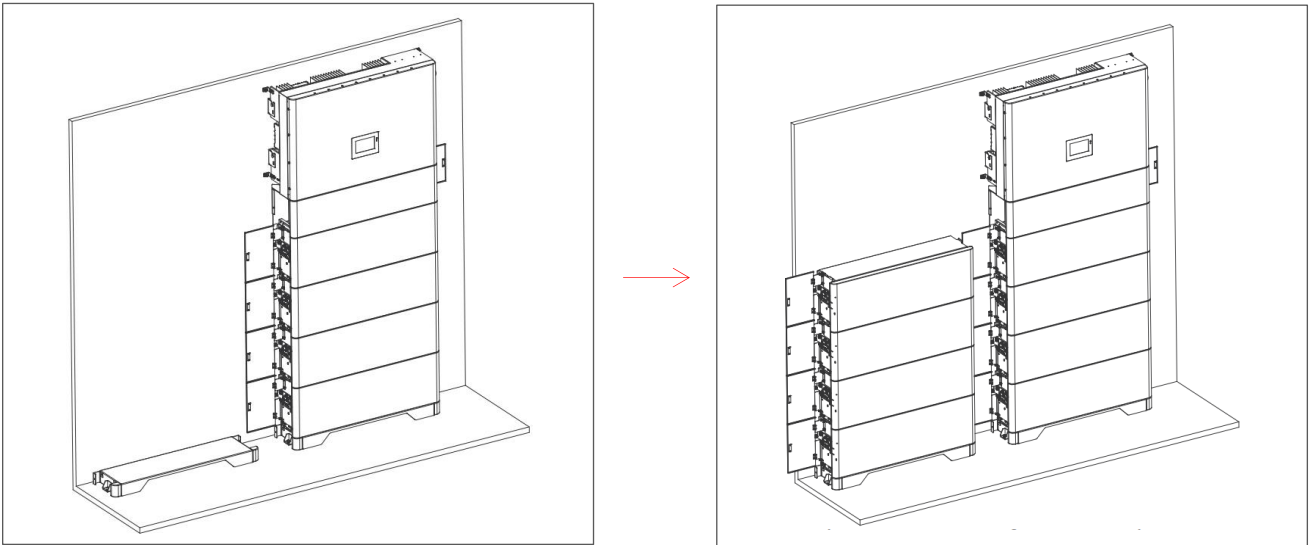

**7. Turn "OFF" The Breakers.**

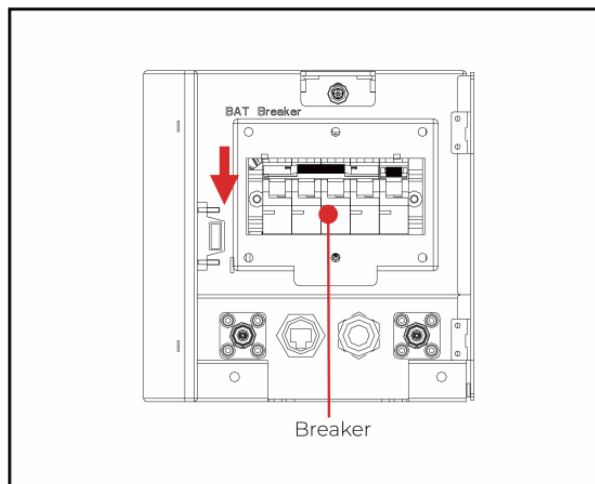

**8. Install the wire protection box**

- ① Assemble the wire protection box, cable bushing, and the left side panel of the high-voltage box into one, and pass the power line and communication line through the cable bushing.
- ② Install the wire protection box above the battery on the left side.

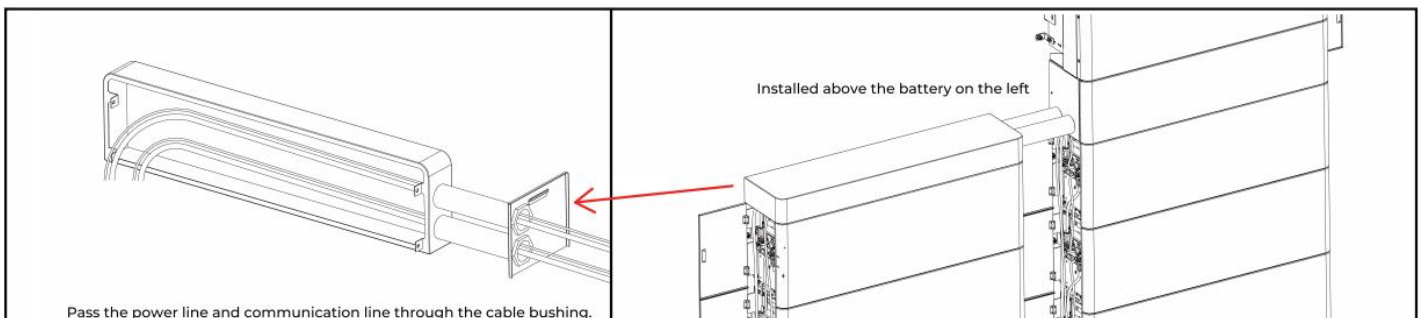

Notice: When installing in double tower mode, you will need conduit to protect exposed cables. Please select conduit that complies with local regulations.

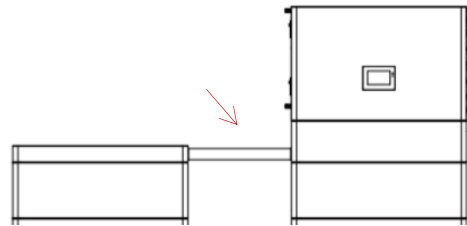

**9.** Tighten the fixing screws on the left and right sides of the wire protection box respectively. (M6\*12 hex phillips (Torque: 8-15 N.m))

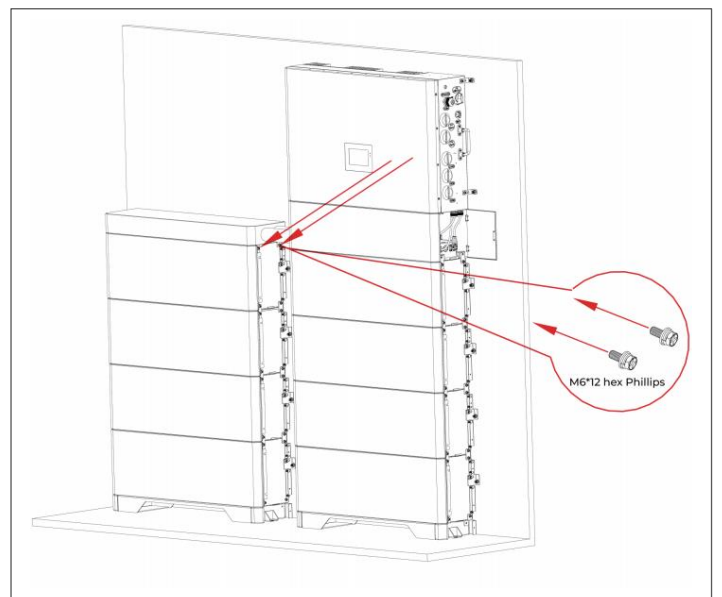
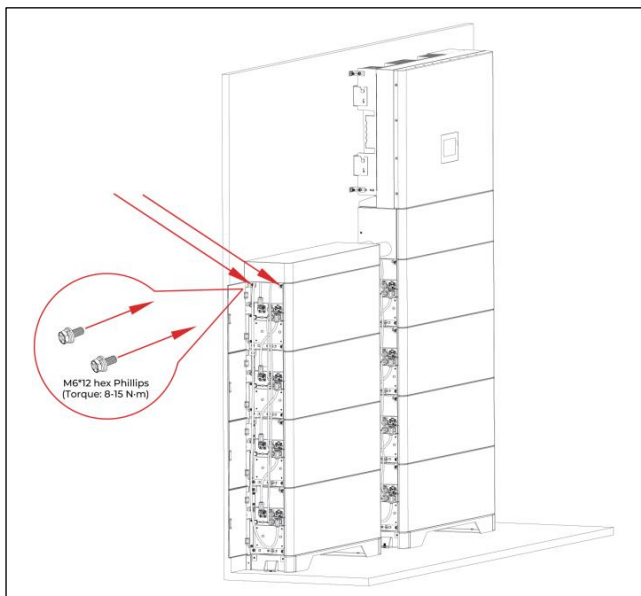

**10.** Tighten the fixing screws on the right panel of the battery. (M5\*10 flat head bolts) (after completing the all-in-one wiring)

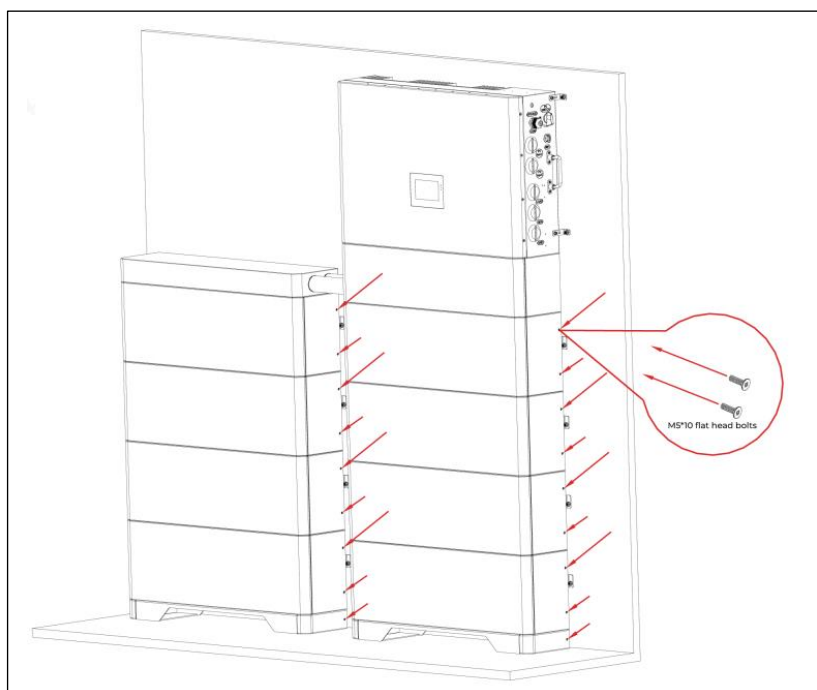

## 4. Electrical connections

Before wiring, please turn “OFF” the breakers.

- All operations, cables, and component specifications used during the electrical connection must comply with local laws and regulations.
- Before making electrical connections, please disconnect the DC switch and AC output switch of the inverter to ensure that the equipment is powered off. **DANGER:** Do not Operate with power on, otherwise there may be dangers such as electric shock.
- Cables of the same type should be bundled together and arranged separately from cables of different types. Intertwining or crossing arrangement is prohibited.
- If the cable bears too much tension, it may lead to poor wiring. When wiring, please reserve a certain length of the cable before connecting it to the inverter wiring port.
- When crimping the terminal, please ensure that the conductor part of the cable is in full contact with the terminal. Do not crimp the cable insulation and the terminal together, otherwise the device may fail to operate, or the device may become overheated due to unreliable connection after operation. The inverter terminal block is damaged, etc.
- When making electrical connections, please wear personal protective equipment such as safety shoes, protective gloves, and insulating gloves as required.
- Only trained professionals are allowed to perform operations related to electrical connection.
- The cable colors in this document are for reference only, and the specific cable specifications must comply with local regulations.
- According to the regulatory requirements of different regions, the N and PE wires of the ON-GRID and BACK-UP ports of the inverter are connected in different ways. For details, the local regulatory requirements shall prevail.
- The ON-GRID and BACK-UP AC ports of the inverter are equipped with internal relays. When the inverter is in the off-grid mode, the built-in ON-GRID relay is in the disconnected state; when the inverter is in the grid-connected mode, the built-in ON-GRID relay is in the closed state.
- When the inverter is powered on, the BACK-UP AC port is charged. If you need to maintain the BACK-UP load, please power off the inverter, otherwise it may cause electric shock.

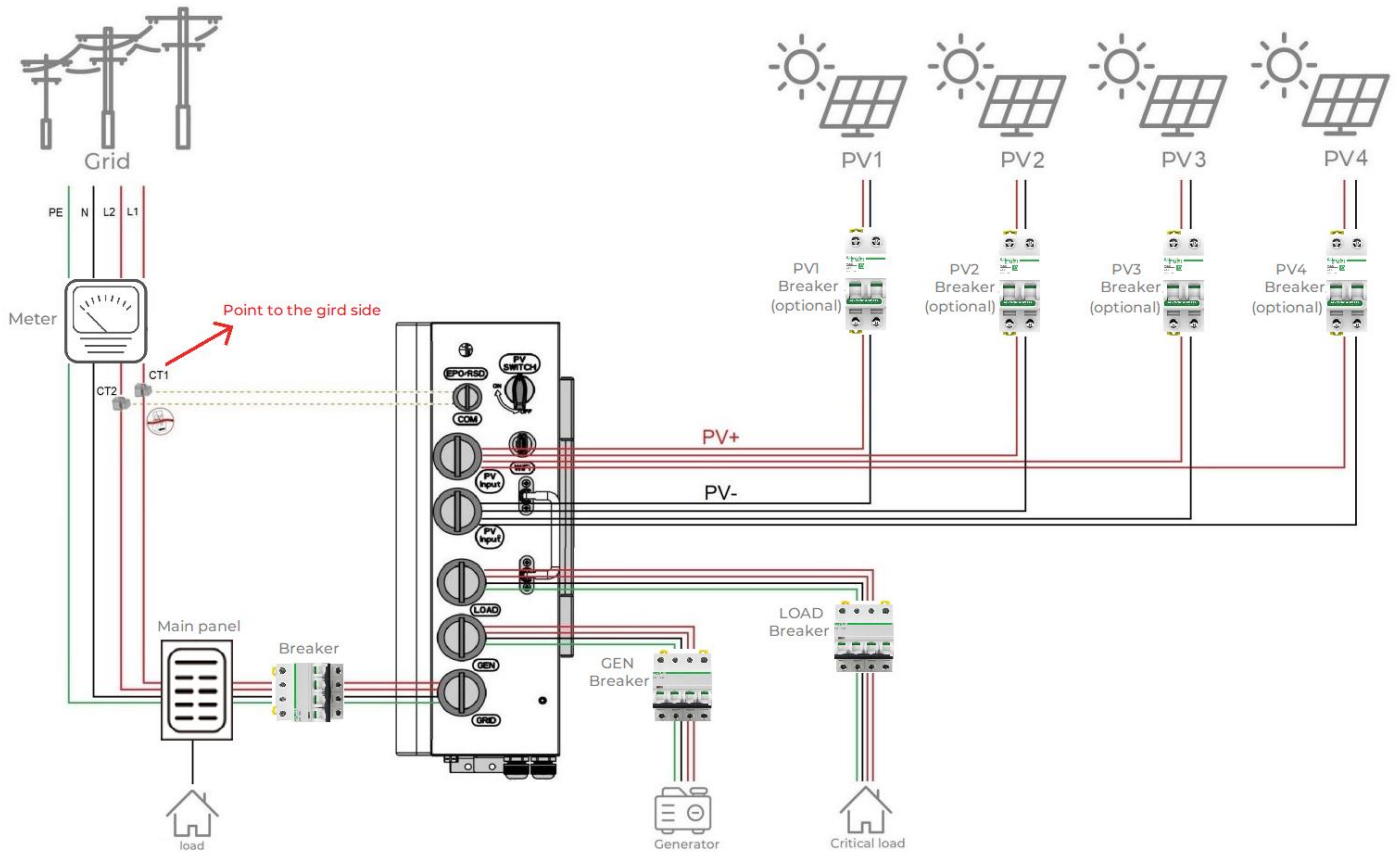
**System Connection Diagram:**

First remove the inverter cover with a screwdriver, and then open the cover of the junction box, as shown in the figure below:

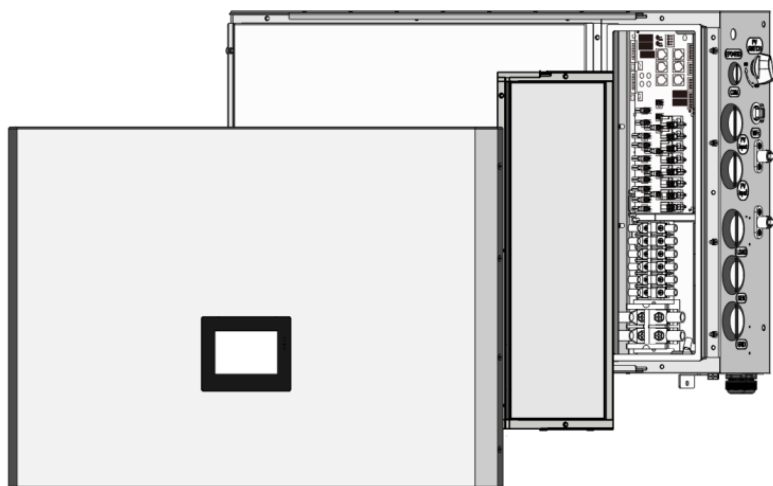

## 4.1 Connect to protective earth

The protective grounding of the chassis shell cannot replace the protective grounding wire of the AC output port. When wiring, ensure that the protective grounding wires of the two places are reliably connected;

When there are multiple inverters, ensure the equipotential connection of the protective grounding points of all inverter chassis shells;

In order to improve the corrosion resistance of the terminal, it is recommended to apply silicone or paint on the outside of the ground terminal for protection after the protective ground connection is installed;

Please bring your own protective ground wire, recommended specifications:

Type: Outdoor Single Core Copper Wire

Conductor cross-sectional area:  $4\text{mm}^2 \leq S \leq 6\text{mm}^2$ .

It is recommended to select a circuit breaker with a rated current of 100A.

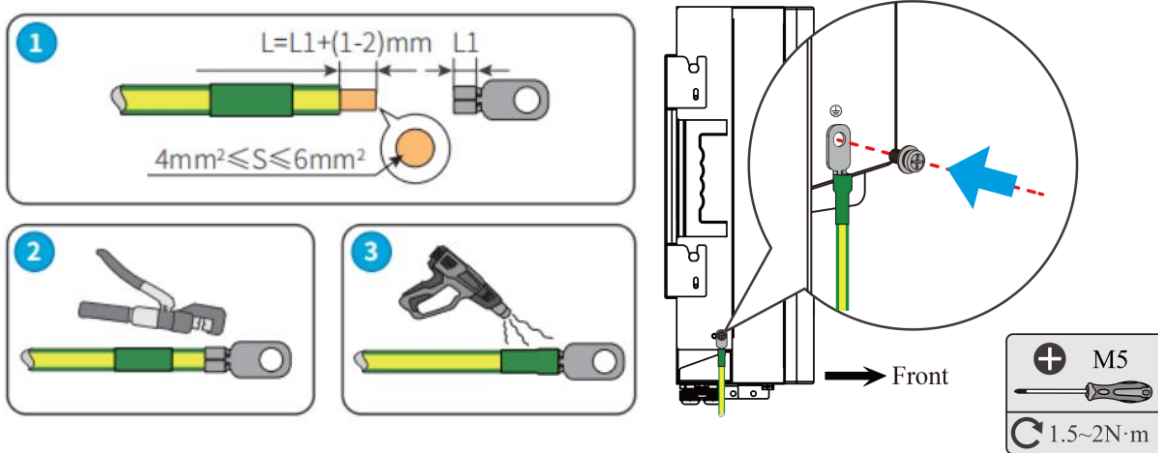

## 4.2 Connecting the DC input cable

### 1. PV wiring

Do not connect the same PV string to multiple inverters, otherwise the inverter may be damaged.

Before connecting the PV strings to the inverter, please confirm the following information:

1) Please ensure that the maximum short-circuit current and maximum input voltage of each MPPT are within the allowable range of the inverter;

2) Please ensure that the positive pole of the PV string is connected to the PV+ of the inverter, and the negative pole of the PV string is connected to the PV- of the inverter;

The PV string output does not support grounding. Before connecting the PV string to the inverter, please ensure that the minimum insulation resistance of the PV string to ground meets the minimum insulation resistance requirement ( $R = \text{maximum input voltage} / 30\text{mA}$ ). Otherwise, the inverter may fail to start.

#### Step 1: Cable production

PV1, PV2, PV3, PV4 use 12AWG cables, remove 18mm of insulation from the end of wire, use terminal fittings to crimp the cables firmly.

It is recommended to select a circuit breaker with a rated current of 100A.

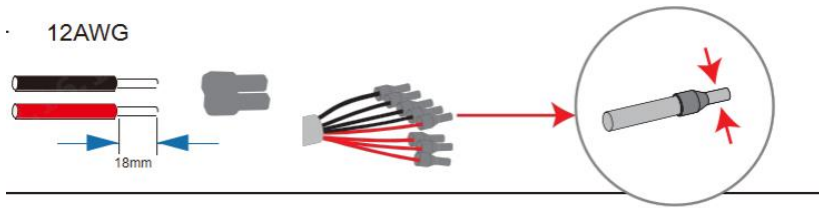

Step 2: Connect the PV input terminals of the inverter

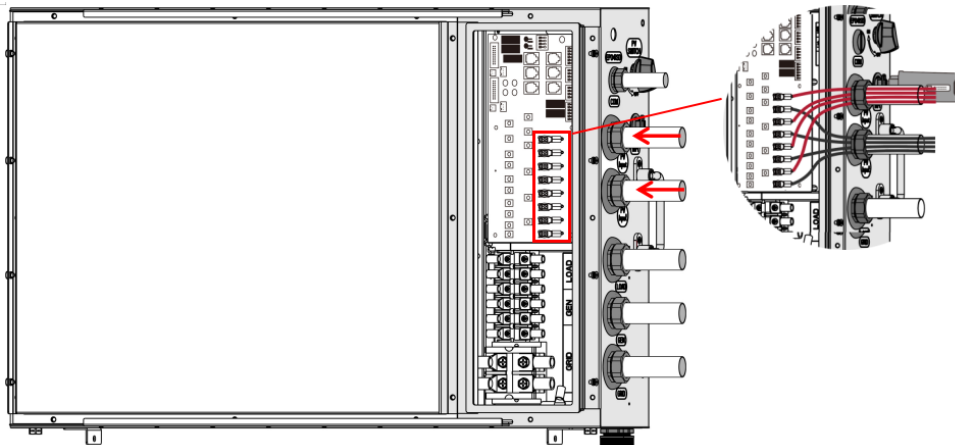

## 2. Battery wiring

The battery cable uses an in-line terminal that goes out directly. Pay attention to the positive and negative of the cable, and connect it directly to the terminal of the battery pack.

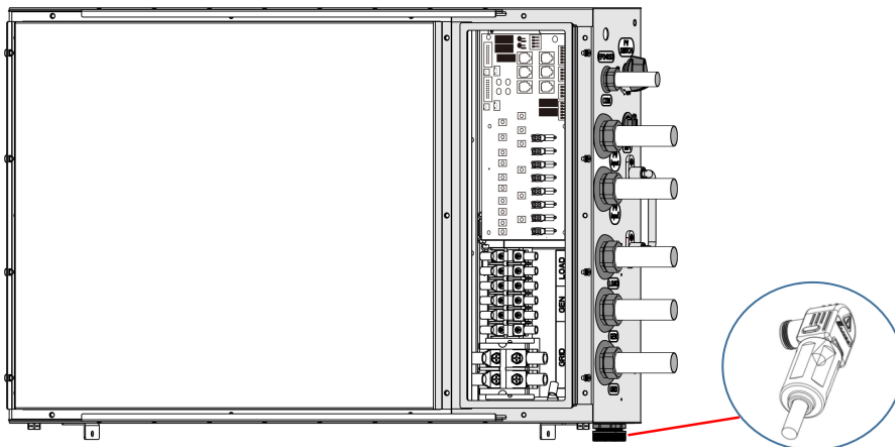

## 4.3 Connecting the AC output cable

It is forbidden to connect loads between the inverter and the AC switch directly connected to the inverter. The inverter integrates a leakage monitoring unit (RCMU) to prevent the residual current from exceeding the specified value.

According to local regulations, a type A RCD can be connected externally to the inverter. Recommended specifications: ON-GRID side: 300mA, BACK-UP side: 30mA. Each inverter needs to be equipped with an AC output circuit breaker, and multiple inverters cannot be connected to the same AC circuit breaker at the same time.

To ensure that the inverter can be safely disconnected from the power grid when an abnormal situation occurs, please connect an AC circuit breaker to the AC side of the inverter. Please select an appropriate AC circuit breaker according to local regulations.

When wiring, the AC line should completely match the "L1", "L2", "N", and the grounding port of the AC terminal. If the cable is connected incorrectly, it will cause equipment damage.

Please ensure that the wire crimping is not exposed;

Please ensure that the insulating plate at the AC terminal is clamped tightly without loosening;

Make sure the cable connection is tight, otherwise the terminal may overheat and damage the device when the device is running;

Make sure that the waterproof wire passes through the waterproof lock or copper pipe and the waterproof lock is tightly sealed;

### 1. Grid electrical connection:

Step 1: Cable production (L1, L2 use 4AWG cables, N wires use 6AWG cables, use terminal fittings to crimp the cables firmly)

It is recommended to select a circuit breaker with a rated current of 100A.



Step 2: Connect the power grid cable to the terminal shown in the figure below, and use a screwdriver to fix and tighten the cable.

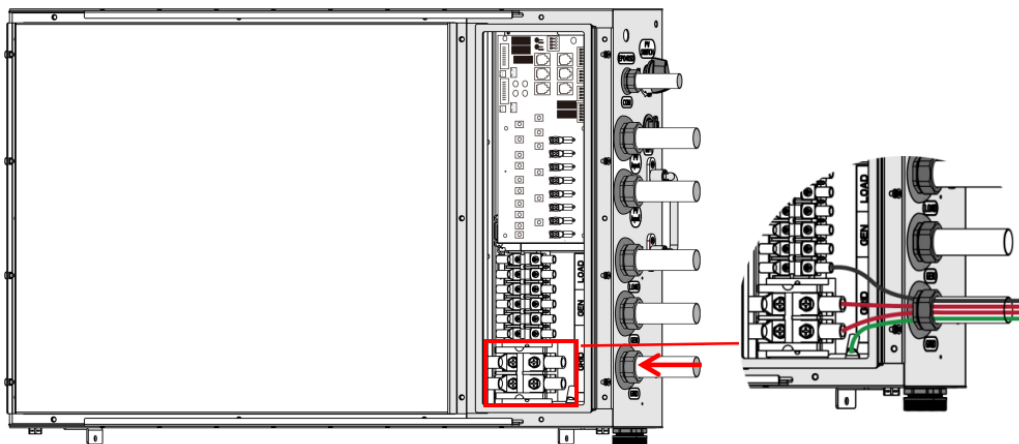

### 2. Load electrical connection:

Step 1: Load cables, use 6AWG, and use accessory terminals to crimp the cables.



Step 2: Connect the load cable to the terminal shown in the figure below of the inverter, and attach it firmly with a screwdriver.

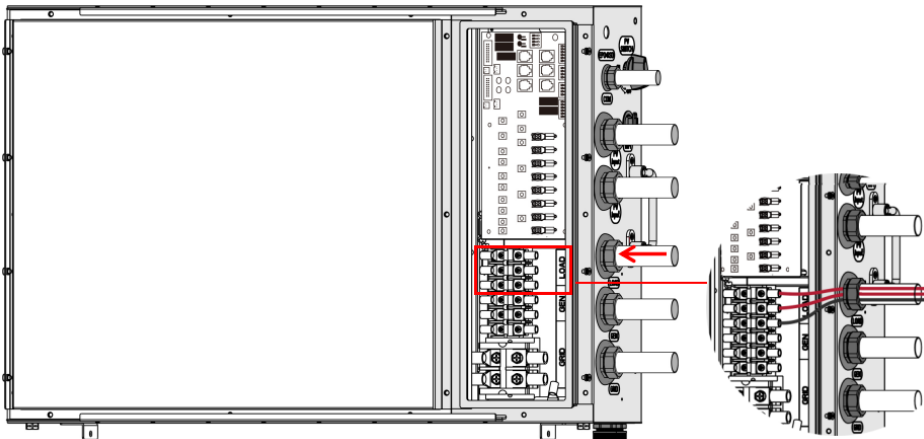

### 3. Generator electrical connection:

Step 1: Generator cable, use 6AWG, accessory terminal to crimp the cable.

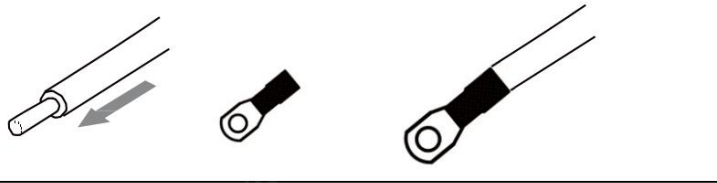

Step 2: Connect the generator input cable to the terminal shown in the figure below of the inverter, and attach it firmly with a screwdriver.

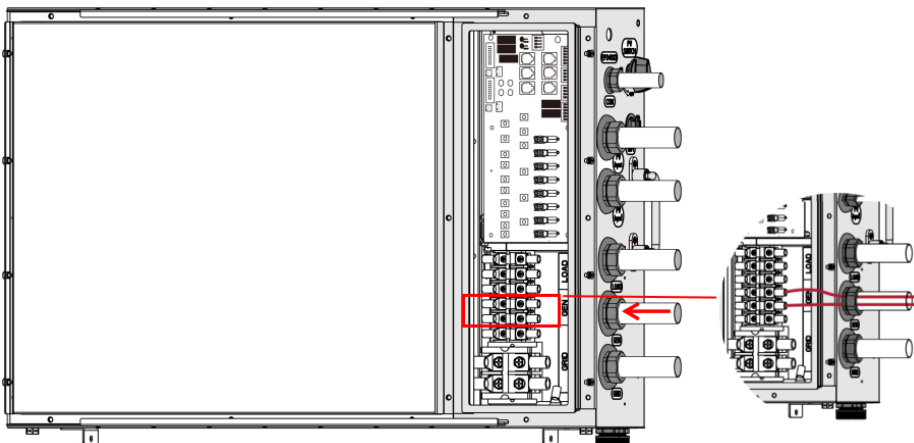

## 4.4 Communication connection

When connecting the communication line, please ensure that the definition of the wiring port matches the device exactly, and the cable routing path avoids interference sources, power lines, etc., so as not to affect signal reception. For details, see the silk screen of the whole machine.

It is recommended to select a circuit breaker with a rated current of 100A.

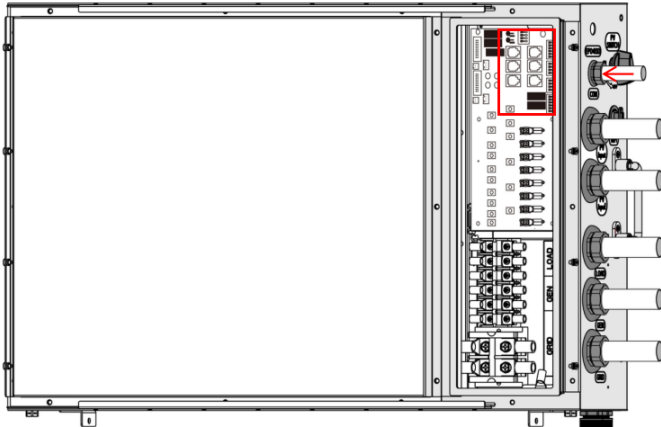

The pin position of the terminal is from left to right, and the left side is pin 1.

No	Port Definition		Function	Functional description
1	J2	1: COM1	Dry contact signal	Used to connect dry contact signals to realize functions such as load and generator control.
		2: NC1		
		3: NO1		
		4: COM2		
		5: NC2		
		6: NO2		
2	J14	1: DI-1	Dry contact signal	Used to connect dry contact signals to realize functions such as load and generator control.
		2: EX-END		
		3: DI-2		
		4: EX-END		
3	J8	1: CT2-GND1	Anti-backflow CT interface	Used to monitor grid-connected transmission power.
		2: CT2.V		
		3: CT1-GND1		
		4: CT1.V		
4	J11	1: EX_485A	External 485 communication	Used when needed to connect to local computer monitoring.
		2: EX_485A		
		3: METER-485A	Meter 485 Communication	External meter communication use.
		4: METER-485B		
		5: EX_12V	12V power supply	External 12V power supply
		6: EX_GND		

#### 4.5 Connect the BMS communication line (RJ45 crystal terminal connection)

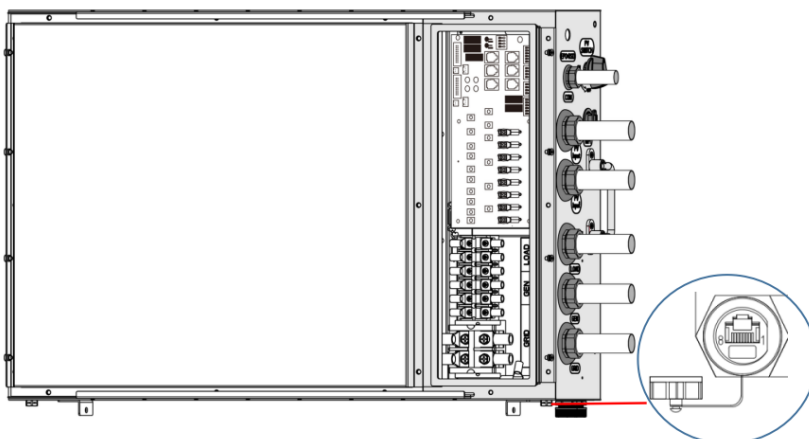

It is recommended to select a circuit breaker with a rated current of 100A.

Support the connection of standard RJ45 crystal plug, the port definition is as follows:

Port Definition	1	2	3	4	5	6	7	8
	CANH	CANL	485A	485B	EPO +	EPO -	12+	GND

## 4.6 Wiring diagram of All-In-One

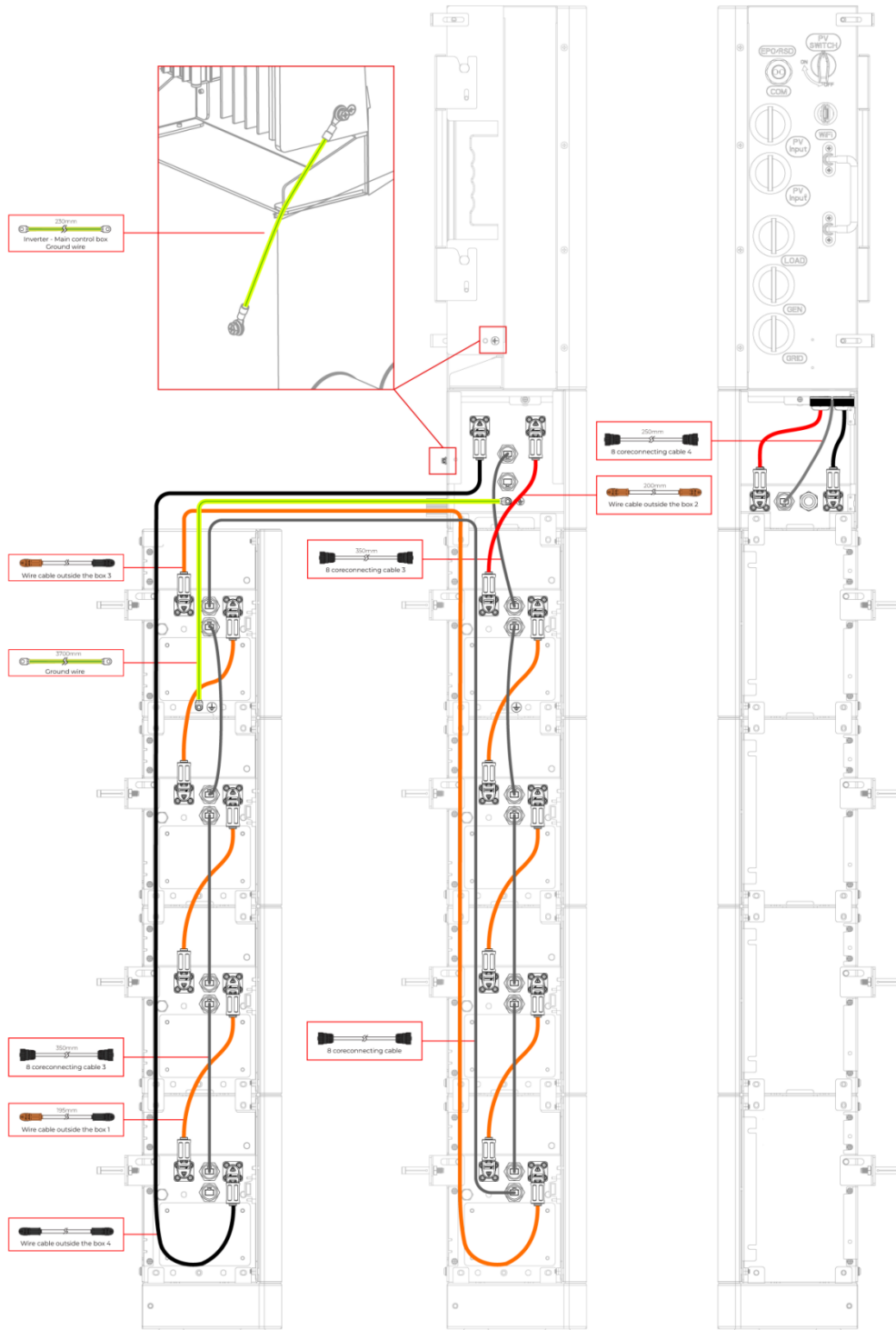

## 4.7 AC coupling function and typical application diagram

The inverter does not need to change its settings, and the AC coupling function can be achieved by wiring according to the following diagram. The diagram is as follows:

Note: The AC coupling function requires the connection of CT. The output line of the grid-connected inverter needs to be connected between this inverter and CT, and the current direction arrow of CT points to the grid.

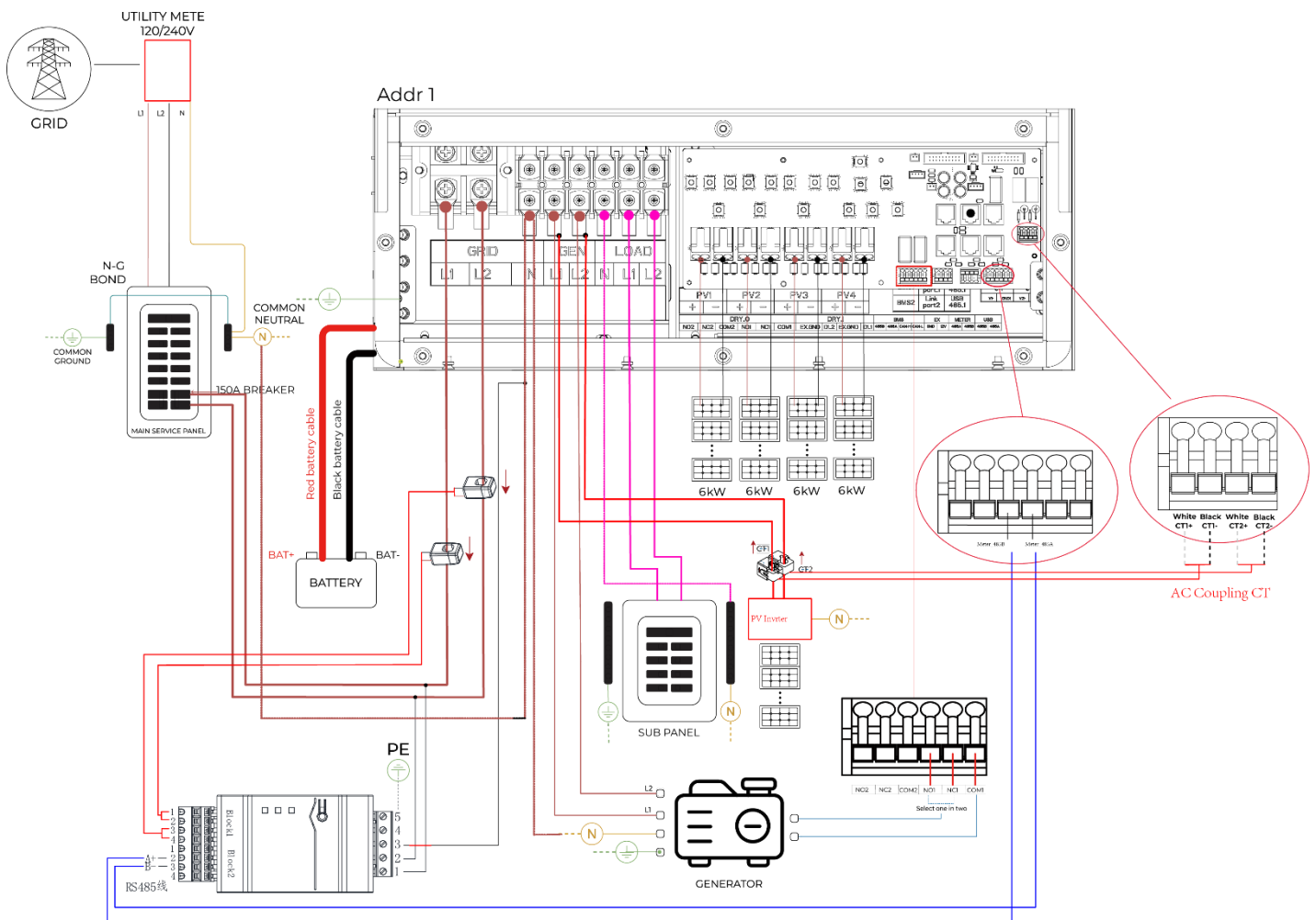

## 4.8 Parallel function and wiring diagram

### 4.8.1 Split-phase parallel

Supports up to 3 parallel connections. The parallel setting needs to be done through the screen.

The host screen setting operation is as follows:

Pull down and select in the parallel setting interface, parallel mode: parallel, parallel represents split parallel; Parallel Address: Addr1, the host address is set to Addr1.

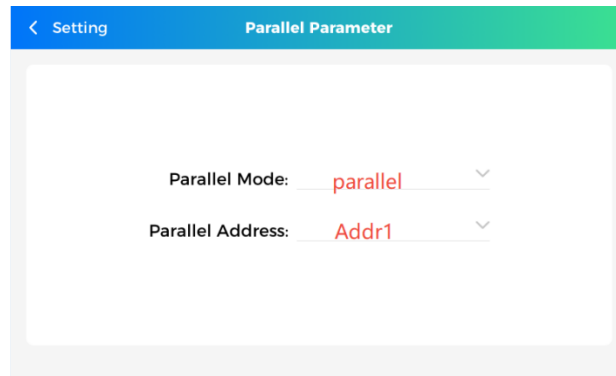

The operation of setting the slave1 screen is as follows:

Select from the pull-down menu of the parallel setting interface, parallel mode: parallel, parallel represents split parallel; Parallel Address: Addr2, the slave1 address is set to Addr2.

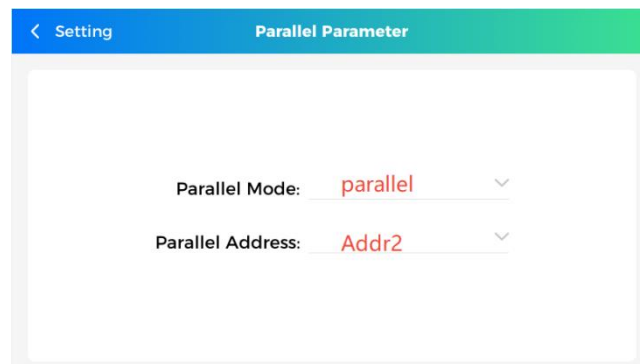

NOTE: If there are 3 units in parallel, the settings of slave 2 refer to slave 1.

The wiring diagram is as follows:

## Generator Mode:

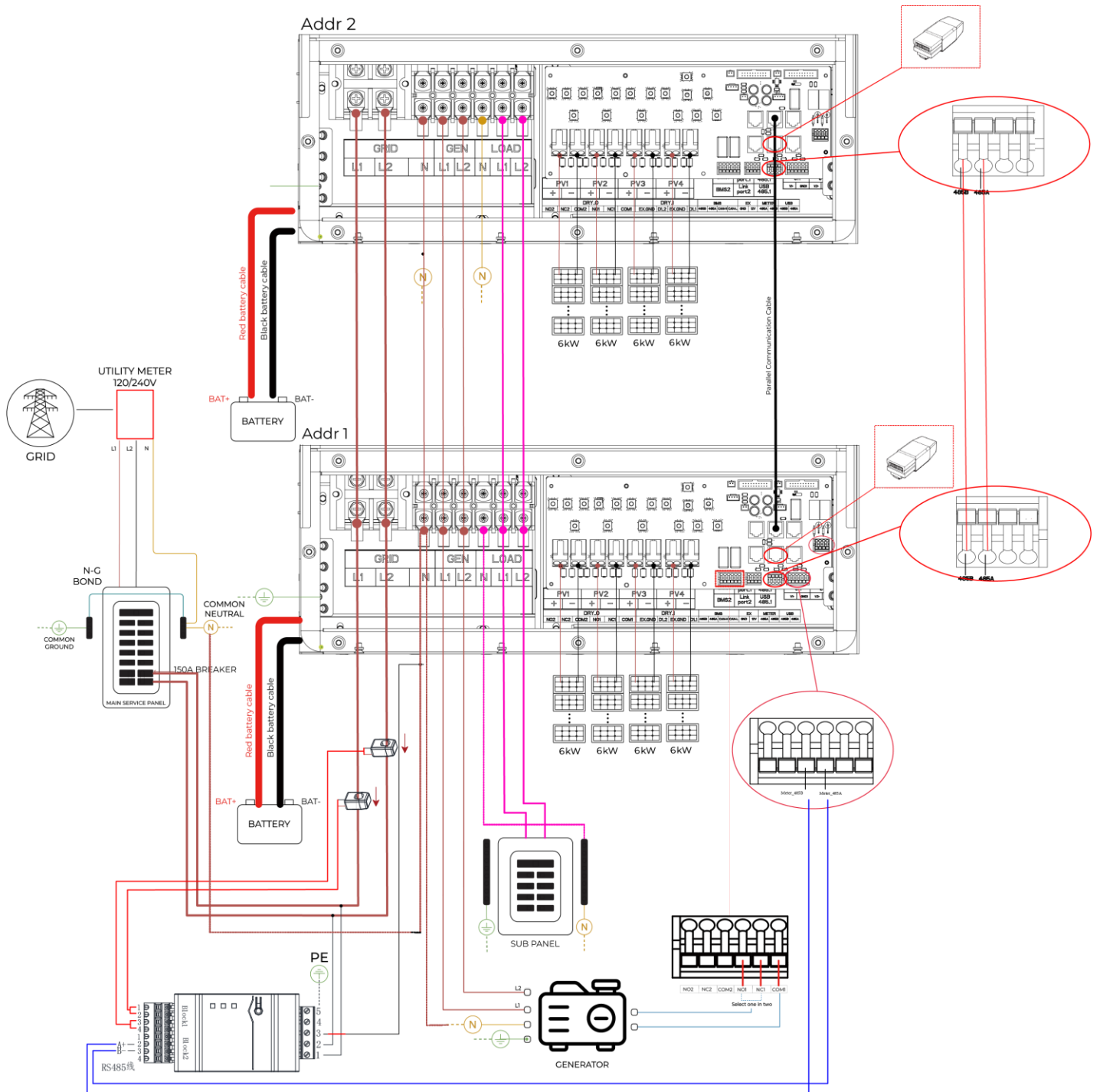

## AC Coupling Mode:

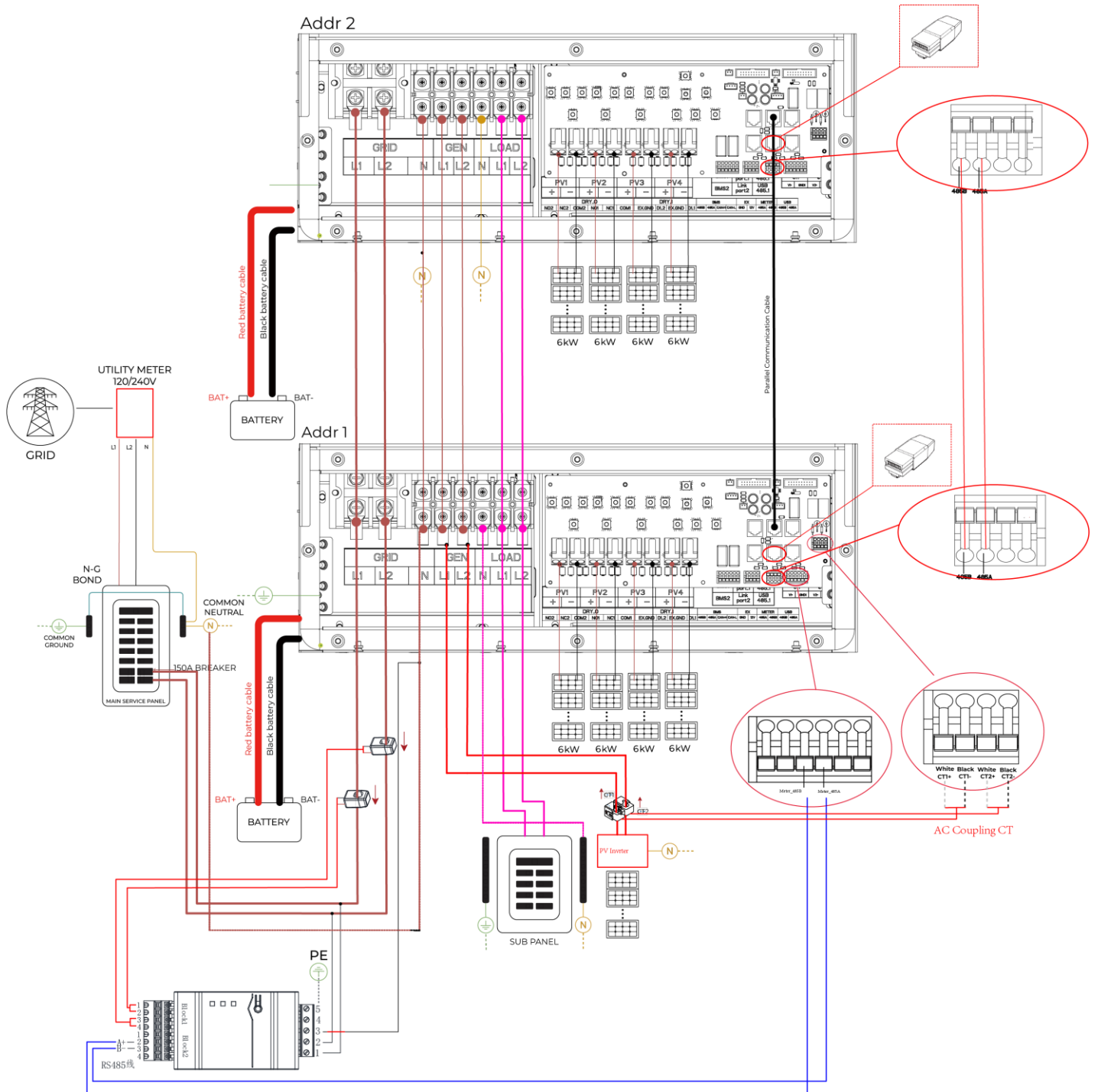

### 4.8.2 Three units in parallel form a three-phase system

The parallel setting needs to be done through the screen.

The host screen setting operation is as follows:

Pull down and select in the parallel setting interface, parallel mode: Three-phase P1, Three-phase P1 represents the host connected in parallel to form a three-phase system; Parallel Address: Addr1, the host address is set to Addr1.

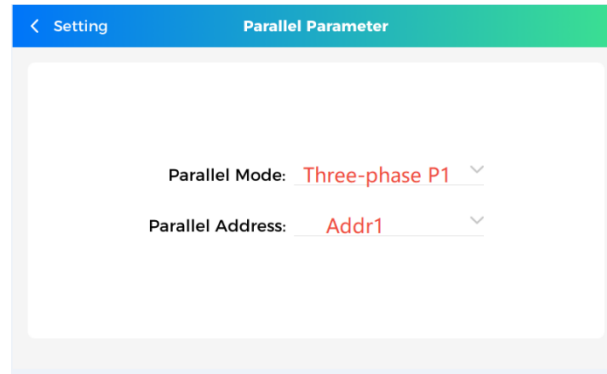

The operation of setting the slave1 screen is as follows:

Select from the pull-down menu of the parallel setting interface, parallel mode: Three-phase P2, Three-phase P2 represents slave1 connected in parallel to form a three-phase system; Parallel Address: Addr2, the slave1 address is set to Addr2.

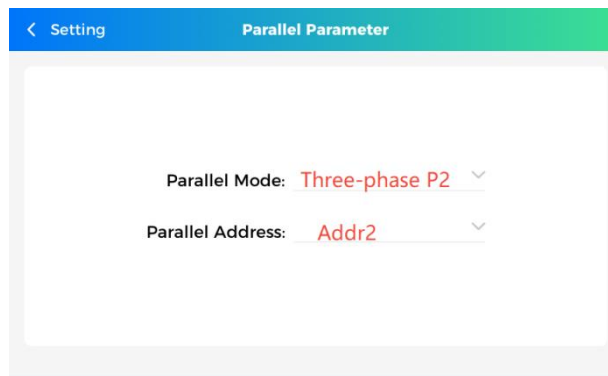

The operation of setting the slave2 screen is as follows:

Select from the pull-down menu of the parallel setting interface, parallel mode: Three-phase P3, Three-phase P3 represents slave2 connected in parallel to form a three-phase system; Parallel Address: Addr3, the slave2 address is set to Addr3.

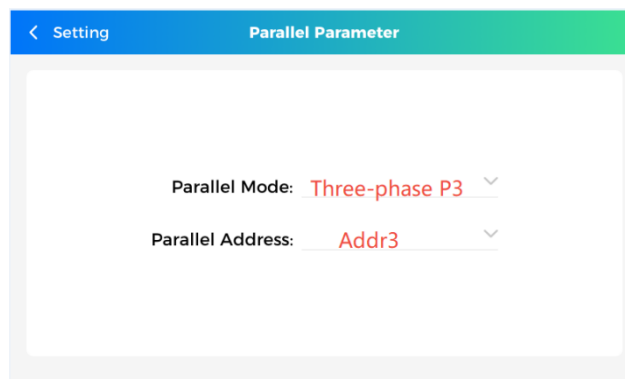

The wiring diagram is as follows:

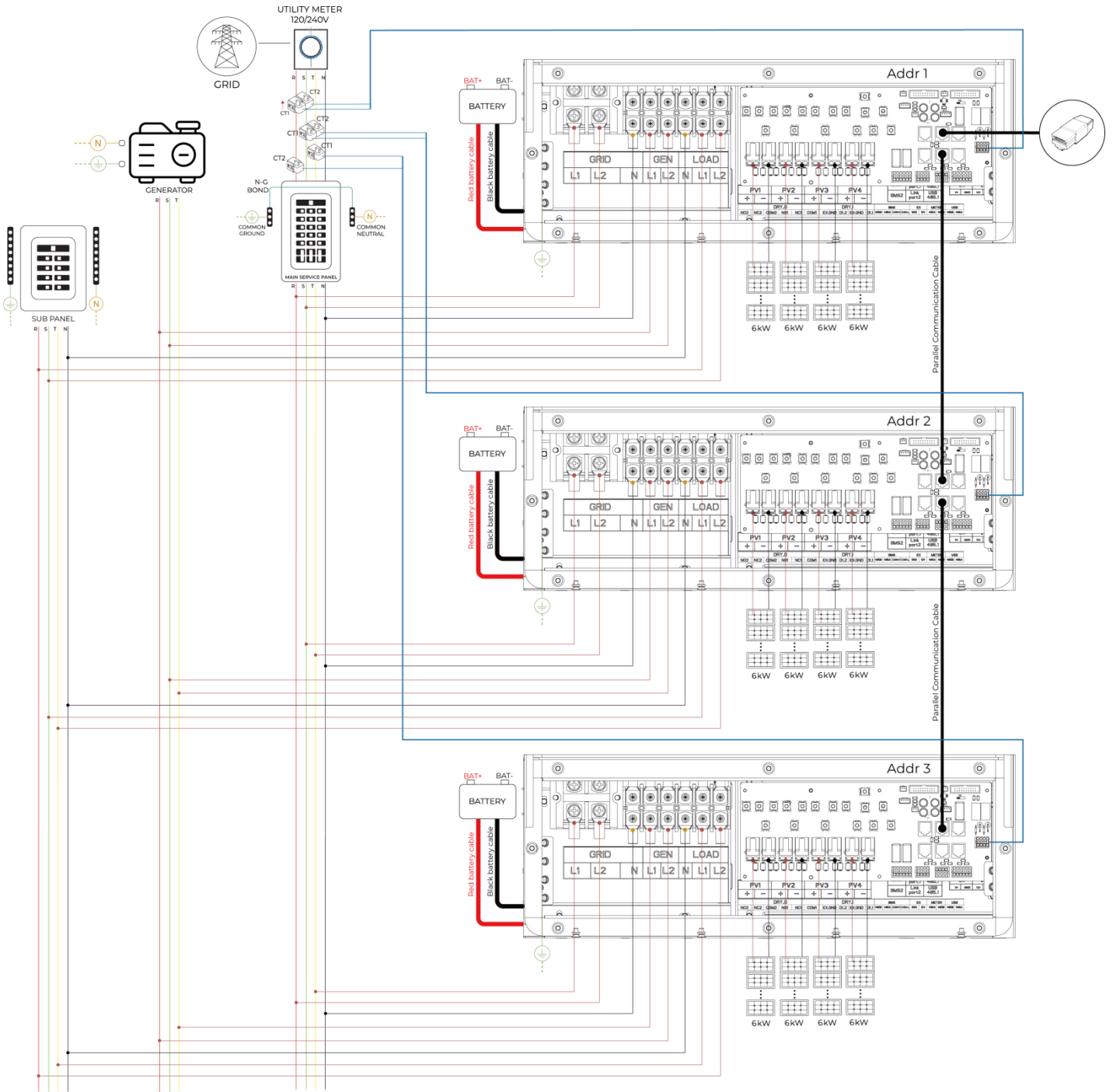

### Wiring instructions:

Host: Grid-L1 is connected to Grid R, Grid-L2 is connected to Grid S, Grid-N is connected to Grid N; Load-L1 is connected to Load R, Load-L2 is connected to Load S, and Load-N is connected to Load N; GEN-L1 is connected to GEN R, GEN -L2 is connected to GEN S;

Slave 1: Grid-L1 is connected to Grid S, Grid-L2 is connected to Grid T, Grid-N is connected to Grid N; Load-L1 is connected to Load S, Load-L2 is connected to Load T, and Load-N is connected to Load N; GEN-L1 is connected to GEN S, GEN -L2 is connected to GEN T;

Slave 2: Grid-L1 is connected to Grid T, Grid-L2 is connected to Grid R, Grid-N is connected to Grid N;

Load-L1 is connected to Load T, Load-L2 is connected to Load R, and Load-N is connected to Load N; GEN-L1 is connected to GEN T, GEN -L2 is connected to GEN R;

## 5. Inverter working mode

### 5.1 Self consume mode

Enter the "Work Mode" menu and select the "SELF CONSUME MODE" work mode. In self-consumption mode, the priority of photovoltaic energy is load>battery>grid, that is, the energy generated by photovoltaics is given priority to the local load, the excess energy is used to charge the battery, and the remaining energy is fed into the grid. There are several cases of self-consumption work mode based on photovoltaic energy:

#### a) Excess PV Energy

When the photovoltaic energy is sufficient, the photovoltaic power supply is given priority to the load, and then the battery is charged, and the excess energy is used for grid-connected power generation.

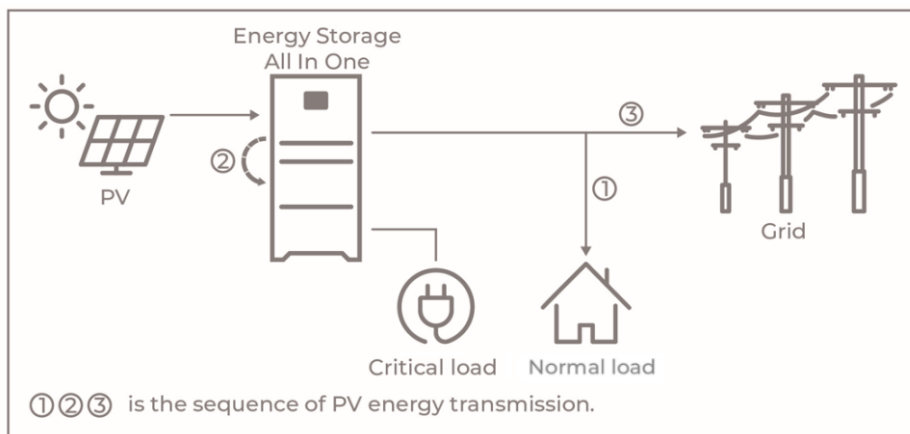

#### b) Limited PV power

When the photovoltaic energy is not enough to cover all the loads, the photovoltaic energy will be used for the loads first, the insufficient part will be supported by the battery, and the remaining insufficient part will be supported by the grid.

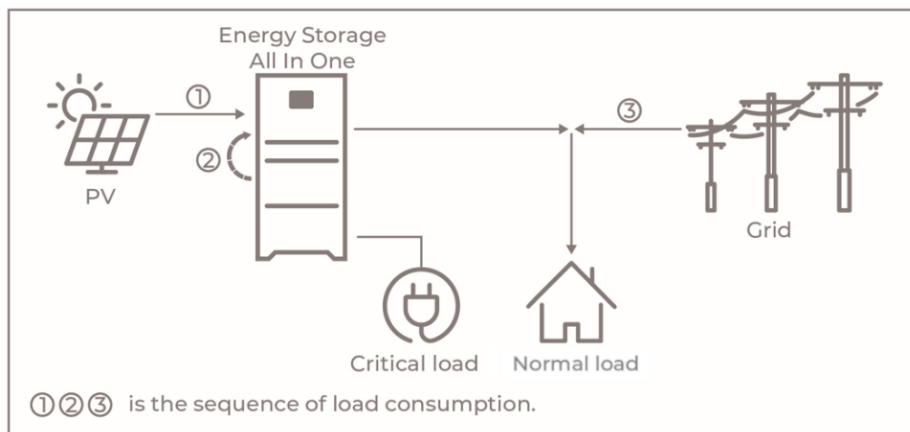

### c) No PV Input

When there is no photovoltaic input (such as evening or rainy day), the inverter will first release battery energy for consumption by household loads, and consume grid energy if the demand is not met.

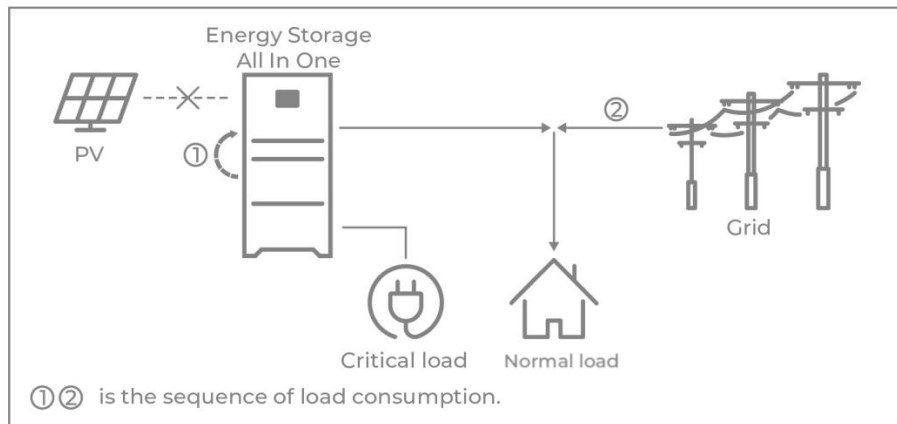

## 5.2 Peak shift mode

Go to the "work mode" menu, and select the "PEAK SHIFT" working mode. Under this mode, you can control the charging and discharging of the inverter. You can set the following parameters based on your requirements:

Priority: battery> load>grid(when charging)

Priority: load>battery>grid (when discharging)

- Charging start time: 0 to 24 hours
- Charging end time: 0 to 24 hours
- Discharge start time: 0 to 24 hours
- Discharge end time: 0 to 24 hours

This mode applies to areas where time of use(TOU) policies are in effect.

User can use off-peak electricity to charge the battery.

The charging and discharging time is flexible, and it also allows to choose whether to charge from the grid or not.

## 5.3 BAT priority

Enter the "mixed working mode" menu and select the "BAT PRIORITY" working mode. In this mode, the priority of photovoltaic energy is battery>load>grid.

This mode is designed to charge the battery quickly, And allows you to choose whether to allow AC power to charge the battery.

### a) Excess PV Energy

When the photovoltaic energy is sufficient, the photovoltaic will charge the battery first, then meet the load, and the rest will be input to the grid.

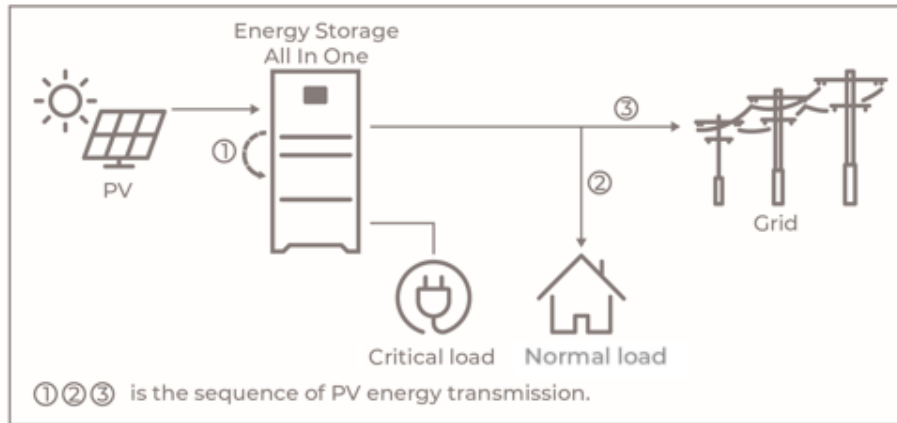

**b) Limited PV power**

When the photovoltaic energy is not enough to charge the battery, the insufficient part is supported by the grid, and the grid energy is used for load consumption.

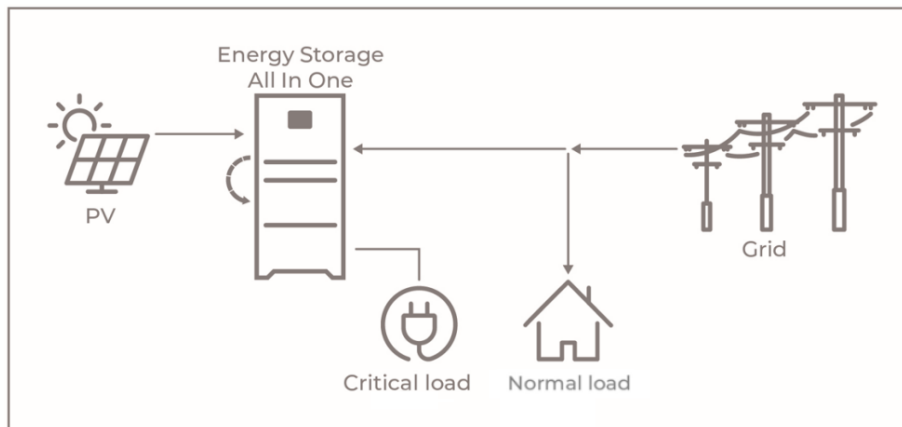

**5.4 Electricity sales mode**

**a) Wealthy PV Energy**

When the photovoltaic energy is sufficient, under the condition of meeting the energy demand of the load, it will be sold to the grid first in accordance with local regulations, and the battery will be charged with any excess energy.

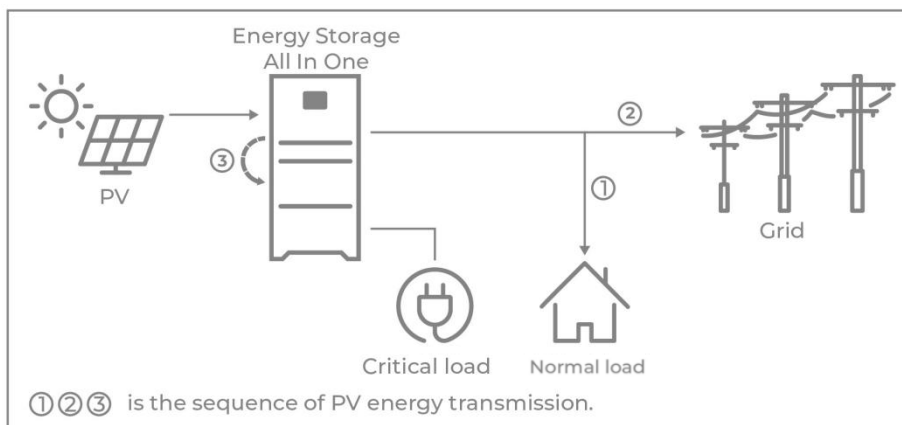

**b) Limited PV power**

When the photovoltaic energy is insufficient, the battery discharges to meet the energy demand of the load, and sells the excess battery power to the grid in accordance with local regulations.

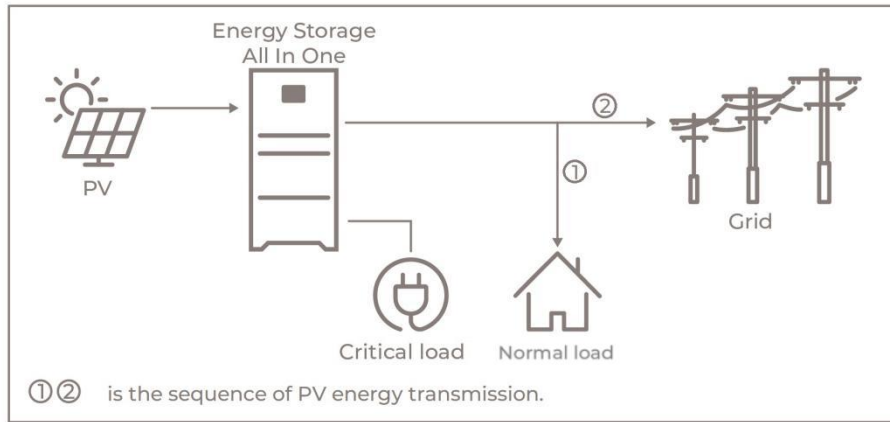

**Note on special circumstances:**

If the main power is cut off or not connected, no matter what mode is set by the user (self-use, peak cutting and valley filling or charging priority), the energy storage inverter is used as emergency power EPS, and the load is powered by the battery and PV of the energy storage transformer. PV preferentially supplies power to the negative grid, and the rest charges the battery. If the PV capacity is insufficient, the battery and PV jointly supply power to the load.

For the 15KW model, the load output port must not exceed 15KW in the inverter mode, and not exceed 20KW in the bypass mode; for the 10KW model, the load output port must not exceed 10KW in the inverter mode, and does not exceed 15KW in the bypass mode.

## 6. Startup/Shutdown the system

### 6.1 Check before power on

No.	Check item
1	The inverter is firmly installed, the installation location is convenient for operation and maintenance, the installation space is convenient for ventilation and heat dissipation, and the installation environment is clean and tidy.
2	The protective ground wire, DC input wire, AC output wire, and communication wire are correctly and firmly connected.
3	The cable binding meets the routing requirements, the distribution is reasonable, and there is no damage.
4	Make sure that the waterproof cover is installed on the unused cable hole.
5	The used cable holes must be sealed.
6	The voltage and frequency of the grid-connected access point of the inverter meet the grid-connected requirements.

## 6.2 Startup the system

Startup steps:

1. Close the high voltage box circuit breaker between the inverter and the battery.
2. Close the PV switch of the inverter.
3. Close the AC breaker on the ON-GRID side of the inverter.
4. Close the AC breaker on the back-up side of the inverter.

## 6.3 Shutdown the system

According to the actual situation, if you need to shut down the running system, please follow the shut-down steps below:

1. Disconnect the AC circuit breaker on the ON-GRID side of the inverter.
2. Disconnect the AC circuit breaker on the BACK-UP side of the inverter.
3. Disconnect the energy storage circuit breaker between the inverter and the battery.
4. Disconnect the PV switch of the inverter.

Note: If you need to disconnect the inverter cables, please wait at least 5 minutes before touching these parts of the inverter.

After the inverter is powered off, it takes a certain amount of time to discharge the internal components. Please wait until the equipment is fully discharged according to the labeling time requirements.

## 7. Commissioning

It is necessary to make a complete commissioning of the inverter system. This will essentially protect the system from fire, electric shock or other damages or injuries.

### 7.1 Inspection

Before commissioning, the operator or installer (qualified person) must carefully inspect the system and ensure that:

- 1) The system is installed correctly and securely according to the contents and prompts in this manual, and there is enough space for operation, maintenance and ventilation;
- 2) All terminals and cables are intact;
- 3) No items shall be left on the inverter or in the specified clearance area;
- 4) The photovoltaic and battery packs are working normally, and the power grid is normal;

### 7.2 System commissioning

- 1) Refer to section 6.2 to start the system and power on the system;
- 2) Set parameters on the display screen according to user needs.

### 7.2.1 LED indicators

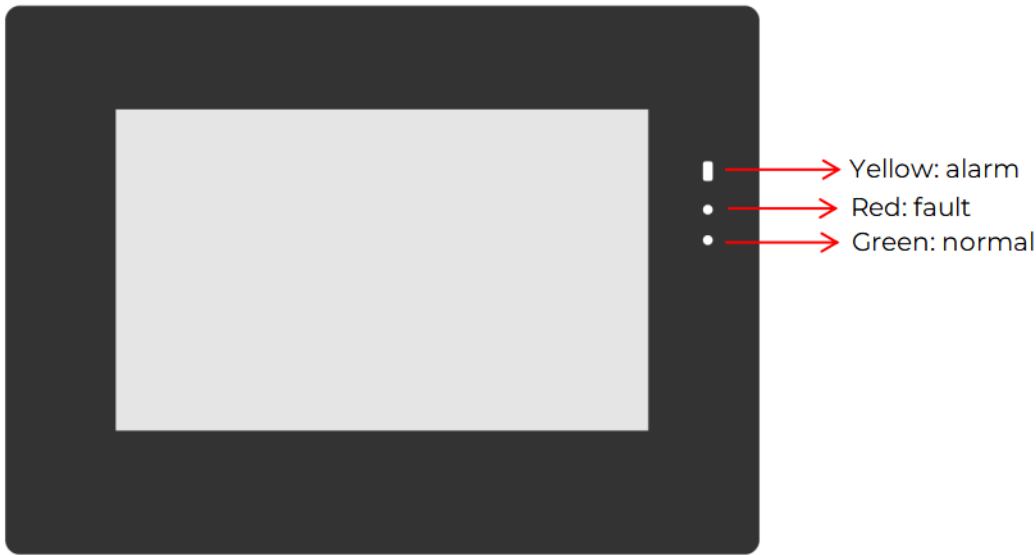

### 7.2.2 Display parameter setting(set on screen)

1. When the inverter is powered on, it shows the initialization page and then turns to the main page.

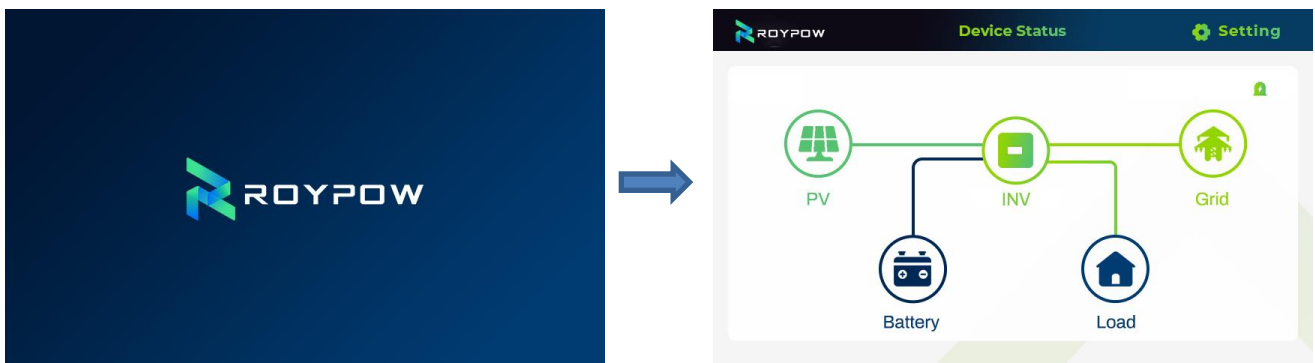

2. Select the PV icon to enter the PV panel parameter display page, click the left and right buttons at the bottom of the page to switch pages and view other parameters.

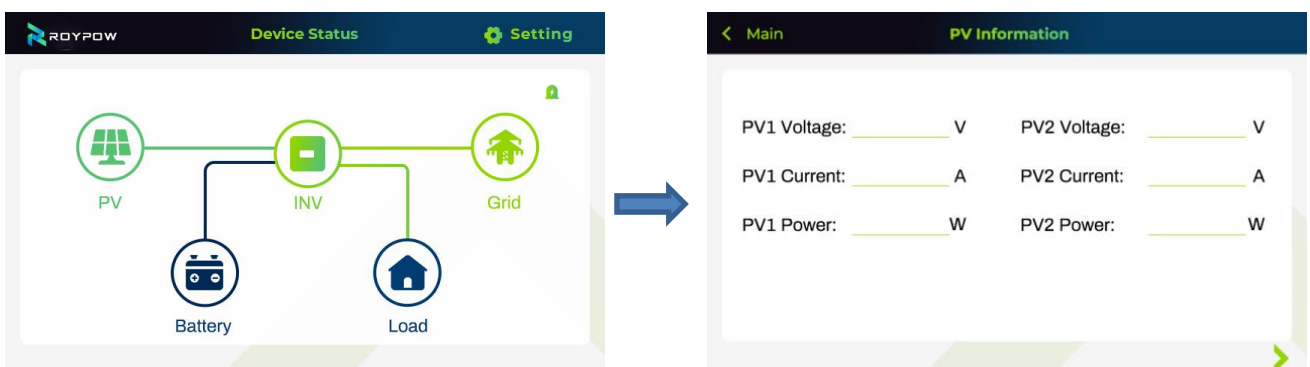

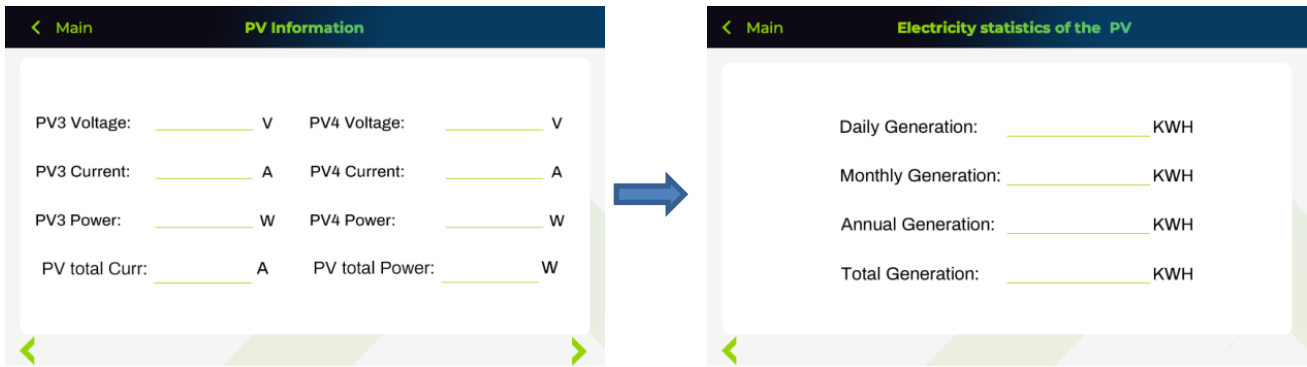

3. Select the grid icon to enter the grid parameter display page, click the left and right buttons at the bottom of the page to switch pages and view other parameters.



4. Select the battery icon to enter the battery parameter display page, click the left and right buttons at the bottom of the page to switch pages and view other parameters.

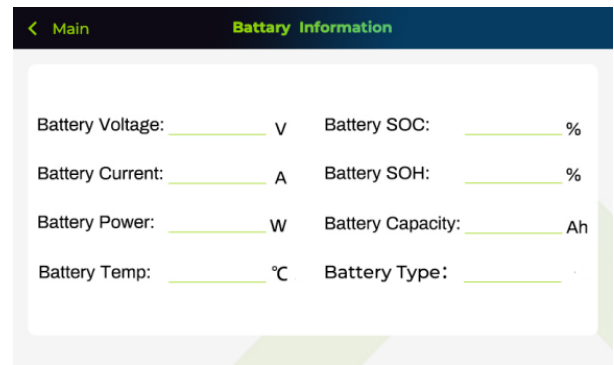
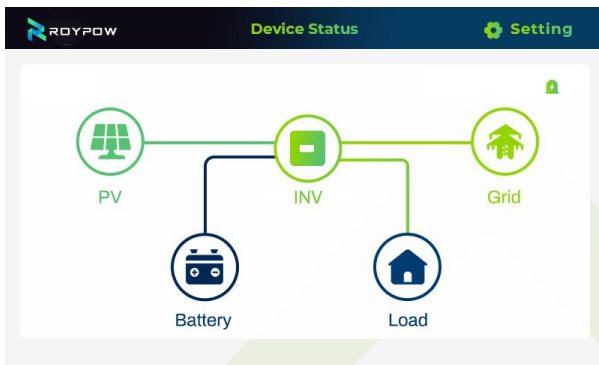

### Load

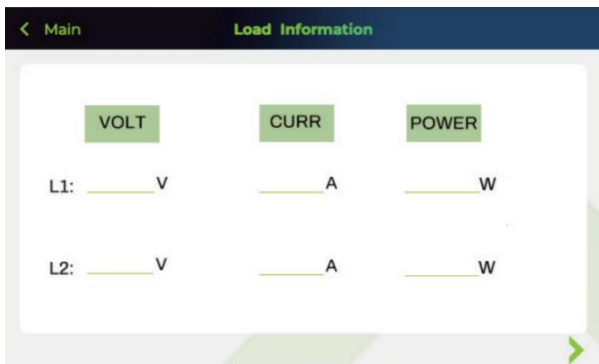

5. Tap the Bell icon in the top right-hand corner to enter the alarm parameter page, click the left and right buttons at the bottom of the page to switch pages, and view other parameters.

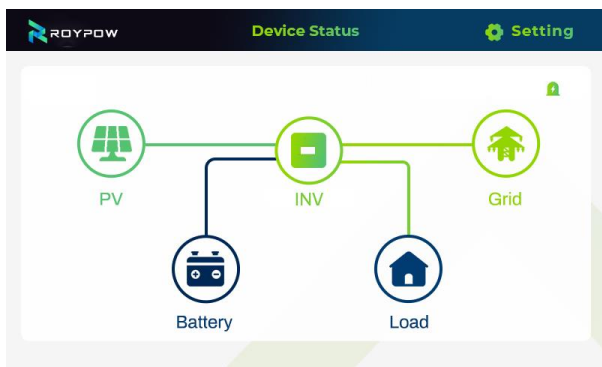

6. Select the setting button in the upper right corner to enter the setting display page, select the working mode to set the working mode of the whole machine and PV input mode; select the machine configuration, you can set and operate the time and date, clear fault records, power on and off, etc.

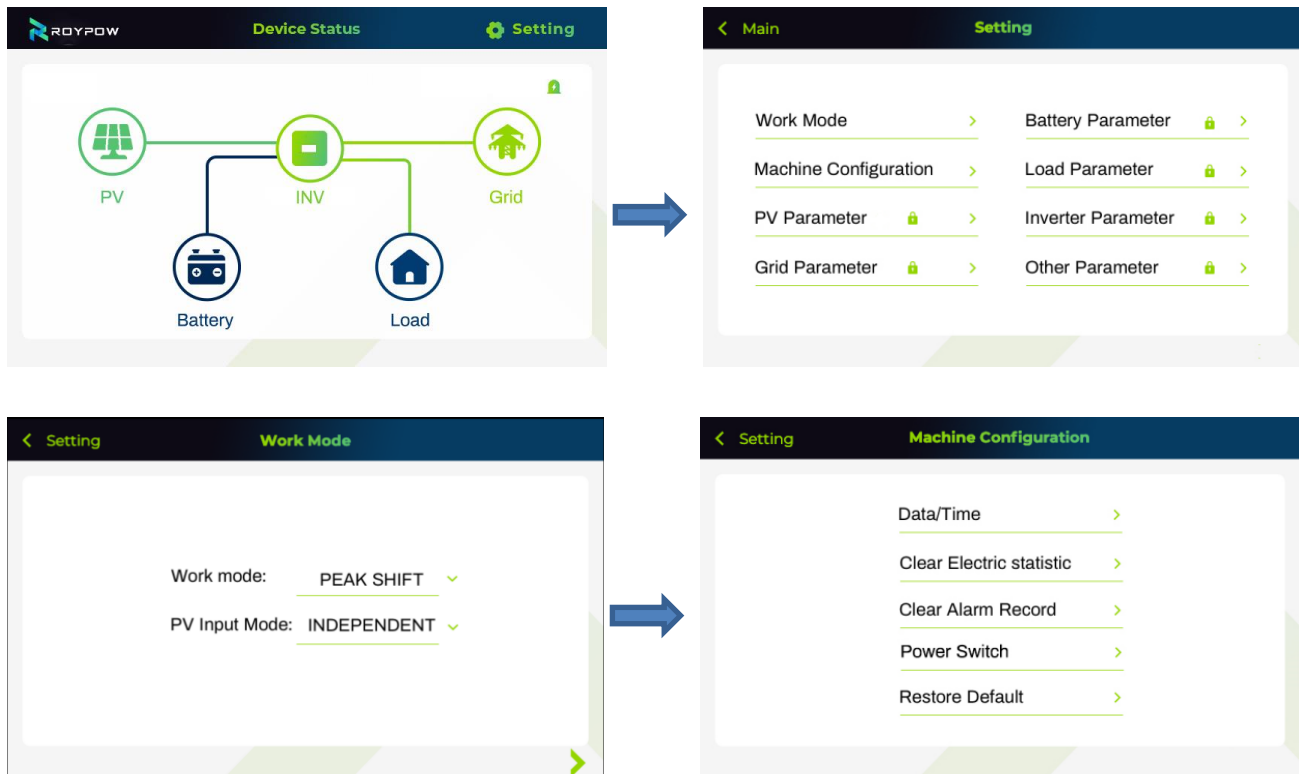

### 7.3 Remote control instructions

1. The content with a lock icon is an operation and maintenance function, and users are not allowed to operate it;
2. Remote control does not involve software upgrades, please refer to the WEB and APP manuals for details;
3. If local maintenance is required, please refer to Section 6.3 for details. Disconnect the remote control first, or remove the acquisition stick.

### 7.4 Cycling capacity 72 hour reset

Based on the requirements for single-family in JA12.3.3.1(e), if the cycling capacity of the BESS drops below the level of the compliance cycling capacity as a result of changes in the reserve level, the BESS shall automatically reset the cycling capacity back to the compliance cycling capacity level after 72 hours. The following is the description of the control strategy and the instructions for operation settings.

The cycling capacity is assigned a default value, which can be adjusted to meet the level of the compliance cycling capacity. During daily operation, the BESS operates based on this cycling capacity. If the owner increases the cycling capacity, the reserve capacity will decrease accordingly. In this case, the cy-

clinging capacity of the BESS exceeds the compliance level, and more capacity will be allocated to daily cycling. Conversely, if the owner decreases the cycling capacity, causing it to fall below the compliance level, a built-in flag will change and trigger a 72-hour countdown. Once the countdown ends, the reserve capacity will be restored to its original default value and displayed to the owner.

operation settings for APP

Step 1: Enter the app of Roypow and locate your machine.

Step 2: Click on "Info" then "Details" to enter the detailed information interface.

Step 3: Click on "DevOps" to enter the operation interface.

Step 4: Click on "Other Settings" to enter the settings interface.

Step 5: Find "BAT DOD" and set the cycling capacity.

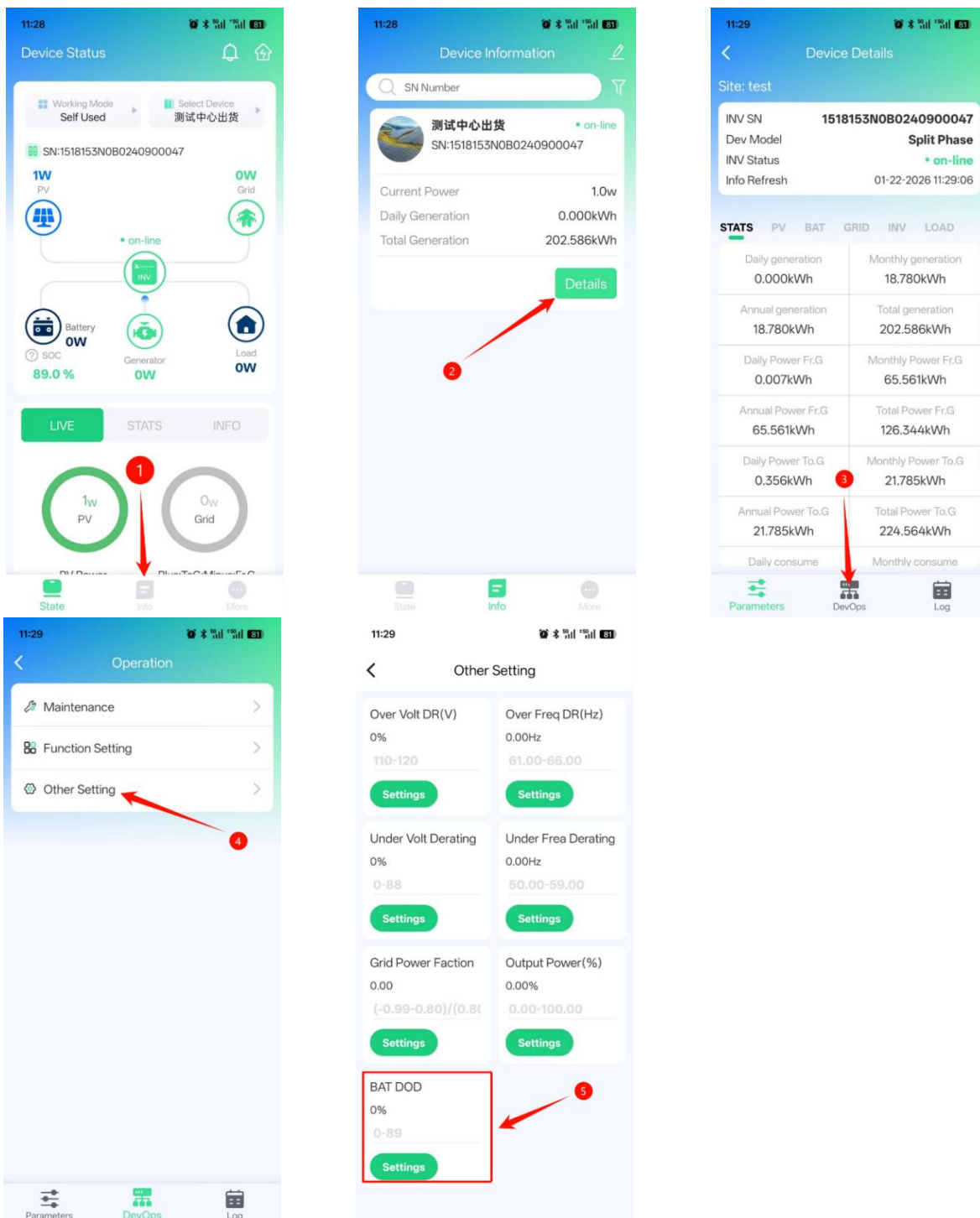

## 8.Maintenance

Please confirm that the equipment is powered off when operating, and wear personal protective equipment.

### 8.1 Routine battery maintenance

<b>maintenance content</b>	<b>maintenance method</b>	<b>Maintenance Interval</b>
System cleaning	Check the cooling fins and air inlet/outlet for foreign objects and dust.	Semiannually
System running status	Observe whether the appearance of the energy storage is damaged or deformed. Listen to whether there is any abnormal sound during the operation of the energy storage. When the energy storage is running, check whether the parameters of the energy storage are set correctly.	Semiannually
Electrical connections	Check whether the cable connection is disconnected or loose. Check whether the cable is damaged, and especially check whether the surface of the cable in contact with the metal surface has cut marks. Check whether the unused DC input terminals, energy storage terminals, COM ports, and waterproof covers are locked.	Semiannually
Grounding reliability	Check whether the grounding cable is reliably grounded.	Semiannually

### 8.2 Inverter routine maintenance

Inverter maintenance distance is 39.37in(1m).

<b>Maintaining Item</b>	<b>Maintaining Method</b>	<b>Maintaining Period</b>
Systematic Clean	Check the heat sink, air intake, and air outlet for foreign matter or dust.	Once 4-6 months
DC switch	Turn the DC switch on and off ten consecutive times to make sure that it is working properly.	Once a year
Electrical connection	Check whether the cables are securely connected. Check whether the cables are broken or whether there is any exposed copper core.	Once 4-6 months
Sealing	Check whether all the cable hole are properly sealed. Reseal the cable hole if it is not sealed or too big.	Once a year

### 8.3 Removing the inverter

Make sure the power is off when operating the inverter, and please wear personal protective equipment. Proceed as follows:

1. Disconnect all electrical connections of the inverter, including: DC wire, AC wire, communication wire, communication module, and protective ground wire.

2. Remove the inverter from the mounting bracket.
3. Remove the mounting bracket.

Please keep the inverter properly. If the inverter needs to be put into use later, ensure that the storage conditions meet the requirements:

- 1) Make sure the storage environment is clean, the temperature and humidity range is suitable, and there is no condensation.
- 2) Make sure that the stacking height and direction of the inverter are placed according to the instructions on the label on the packing box.
- 3) Ensure that there is no risk of dumping after the inverters are stacked.
- 4) After the inverter has been stored for a long time, it must be checked and confirmed by professionals before it can continue to be used.

## 9. Troubleshooting

Perform troubleshooting according to the following methods. Contact the after-sales service if these methods do not work. Collect the information below before contacting the after-sales service for faster service. Fault information will be displayed on the inverter display.

1. Inverter information such as serial number, software version, installation date, fault time, fault frequency, etc.
2. Installation environment, including weather conditions, whether the PV modules are sheltered or shadowed, etc. It is recommended to provide some photos and videos to assist in analyzing the problem.
3. When fault occurs, the buzzer will work; When the fault disappears, the buzzer will stop working, or the system will restart after being powered off, and the buzzer will also stop working.
4. Utility grid situation.

No.	Code	Name (orange is Alarm, red is Fault)	Reason	Soution
1	ID-42	Relay Short	<ol style="list-style-type: none"> <li>1. The relay is abnormal or short-circuited.</li> <li>2. The control circuit is abnormal.</li> <li>3. The AC cable connection is abnormal, like a virtual connection or short circuit</li> </ol>	<ol style="list-style-type: none"> <li>1. Disconnect the AC output switch and DC input switch, then connect them 5 minutes later.</li> <li>2. Contact the dealer or the after-sales service if the problem persists.</li> </ol>
2	ID-45	Relay Break	/	Restart the system, Contact the dealer or the after-sales service if the problem persists.

3	ID-52	High Grid Freq Class 1	Utility grid exception. The actual grid frequency exceeds the requirement of the local grid standard.	<ol style="list-style-type: none"> <li>If the problem occurs occasionally, the utility grid may be abnormal temporarily. The inverter will recover automatically after detecting that the utility grid is normal.</li> <li>If the problem occurs frequently, check whether the grid frequency is within the permissible range. <ul style="list-style-type: none"> <li>Contact the local power company if the grid frequency exceeds the permissible range.</li> <li>Modify the overfrequency protection threshold or disable the overfrequency protection function after obtaining the consent of the local power company if the grid frequency is within the permissible range.</li> </ul> </li> </ol>
4	ID-53	Low Grid Freq Class 1	Utility grid exception. The actual grid frequency is lower than the requirement of the local grid standard.	<ol style="list-style-type: none"> <li>If the problem occurs occasionally, the utility grid may be abnormal temporarily. The inverter will recover automatically after detecting that the utility grid is normal.</li> <li>If the problem occurs frequently, check whether the grid frequency is within the permissible range. <ul style="list-style-type: none"> <li>Contact the local power company if the grid frequency exceeds the permissible range.</li> <li>Modify the overfrequency protection threshold or disable the overfrequency protection function after obtaining the consent of the local power company if the grid frequency is within the permissible range.</li> </ul> </li> </ol>
5	ID-54	L1 Grid Volt RMS OV Class 1	The grid voltage exceeds the permissible range, or the duration of high voltage exceeds the limit of HVRT.	<ol style="list-style-type: none"> <li>If the problem occurs occasionally, the utility grid may be abnormal temporarily. The inverter will recover automatically after detecting that the utility grid is normal.</li> <li>If the problem occurs frequently, check whether the grid voltage is within the permissible range. <ul style="list-style-type: none"> <li>Contact the local power company if the grid voltage exceeds the permissible range.</li> <li>Modify the overvoltage protection threshold, HVRT or disable the overvoltage protection function after obtaining the approval of the local power company if the grid frequency is within the permissible range.</li> </ul> </li> <li>Check whether the AC breaker and the output cables are connected securely and correctly if the problem cannot be solved.</li> </ol>
6	ID-55	L2 Grid Volt RMS OV Class 1	/	Restart the system, Contact the dealer or the after-sales service if the problem persists.
7	ID-57	L1 Grid Volt RMS UV Class 1	The grid voltage is lower than the permissible range, or the duration of low voltage exceeds the requirement of LVRT.	<ol style="list-style-type: none"> <li>If the problem occurs occasionally, the utility grid may be abnormal temporarily. The inverter will recover automatically after detecting that the utility grid is normal.</li> <li>If the problem occurs frequently, check whether the grid voltage is within the permissible range. <ul style="list-style-type: none"> <li>Contact the local power company if the grid voltage exceeds the permissible range.</li> <li>Modify the grid overvoltage rapid protection threshold after obtaining the consent of the local power company if the grid voltage is within the permissible range.</li> </ul> </li> <li>Check whether the AC breaker and the output cables are connected securely and correctly if the problem persists.</li> </ol>

8	ID-58	L2 Grid Volt RMS UV Class 1	/	Restart the system, Contact the dealer or the after-sales service if the problem persists.
9	ID-63	On Grid Curr DCC OC	/	Restart the system, Contact the dealer or the after-sales service if the problem persists.
10	ID-64	Grid Offline	<ol style="list-style-type: none"> <li>Utility grid power fails.</li> <li>The AC cable is disconnected, or the AC breaker is off.</li> </ol>	<ol style="list-style-type: none"> <li>The alarm disappears automatically after the grid power supply is restored.</li> <li>Check whether the AC cable is connected Reasonand the AC breaker is on.</li> </ol>
11	ID-65	Pos Bus Peak OV	<ol style="list-style-type: none"> <li>The PV voltage is too high.</li> <li>The sampling of the inverter BUS voltage is abnormal.</li> </ol>	<ol style="list-style-type: none"> <li>Disconnect the AC output switch and DC input switch, then connect them 5 minutes later.</li> <li>Contact the dealer or the after-sales service if the problem persists.</li> </ol>
12	ID-66	Neg Bus Peak OV	/	Restart the system, Contact the dealer or the after-sales service if the problem persists.
13	ID-67	L1 Inv Curr Peak OC	/	Restart the system, Contact the dealer or the after-sales service if the problem persists.
14	ID-68	L2 Inv Curr Peak OC	/	Restart the system, Contact the dealer or the after-sales service if the problem persists.
15	ID-70	Bus Volt Peak Imbalance	/	Restart the system, Contact the dealer or the after-sales service if the problem persists.
16	ID-71	Inv Curr Peak Short	/	Restart the system, Contact the dealer or the after-sales service if the problem persists.
17	ID-72	L1 Inv Volt RMS OV	/	Restart the system, Contact the dealer or the after-sales service if the problem persists.
18	ID-73	L2 Inv Volt RMS OV	/	Restart the system, Contact the dealer or the after-sales service if the problem persists.
19	ID-78	L1 Load Curr RMS OC Class 1	/	Restart the system, Contact the dealer or the after-sales service if the problem persists.
20	ID-79	L2 Load Curr RMS OC Class 1	/	Restart the system, Contact the dealer or the after-sales service if the problem persists.
21	ID-81	L1 Load Curr RMS OC Class 2	/	Restart the system, Contact the dealer or the after-sales service if the problem persists.
22	ID-82	L2 Load Curr RMS OC Class 2	/	Restart the system, Contact the dealer or the after-sales service if the problem persists.
23	ID-84	L1 Load Curr RMS OC Class 3	/	Restart the system, Contact the dealer or the after-sales service if the problem persists.
24	ID-85	L2 Load Curr RMS OC Class 3	/	Restart the system, Contact the dealer or the after-sales service if the problem persists.
25	ID-87	L1 Gen. Volt RMS OV	/	Restart the system, Contact the dealer or the after-sales service if the problem persists.
26	ID-88	L2 Gen. Volt RMS OV	/	Restart the system, Contact the dealer or the after-sales service if the problem persists.
27	ID-90	Pos Bus Volt RMS OV	/	Restart the system, Contact the dealer or the after-sales service if the problem persists.
28	ID-91	Neg Bus Volt RMS OV	/	Restart the system, Contact the dealer or the after-sales service if the problem persists.
29	ID-92	Pos Bus Volt RMS UV	/	Restart the system, Contact the dealer or the after-sales service if the problem persists.
30	ID-93	Neg Bus Volt RMS UV	/	Restart the system, Contact the dealer or the after-sales service if the problem persists.
31	ID-96	Bus Volt RMS Imbalance	/	Restart the system, Contact the dealer or the after-sales service if the problem persists.
32	ID-97	OffGrid Volt DCC OV	/	Restart the system, Contact the dealer or the after-sales service if the problem persists.

33	ID-98	Leak Curr Fault (On Grid)	The input insulation impedance to earth becomes low when the inverter is working.	<ol style="list-style-type: none"> <li>If the problem occurs occasionally, it may be caused by a cable exception. The inverter will recover automatically after the problem is solved.</li> <li>Check whether the impedance between the PV string and PE is too low if the problem occurs frequently or persists</li> </ol>
34	ID-99	Island Fault	The utility grid is disconnected. The utility grid is disconnected according to the safety regulations, but the grid voltage is maintained due to the loads.	<ol style="list-style-type: none"> <li>Check whether the utility grid is disconnected.</li> <li>Contact the dealer or the after-sales service.</li> </ol>
35	ID-101	HVRT Fault	Utility grid exception. The duration of utility grid exception exceeds the set time of HVRT.	<ol style="list-style-type: none"> <li>If the problem occurs occasionally, the utility grid may be abnormal temporarily. The inverter will recover automatically after detecting that the utility grid is normal.</li> <li>If the problem occurs frequently, check whether the grid frequency is within the permissible range. If not, contact the local power company. If yes, contact the dealer or the after-sales service.</li> </ol>
36	ID-102	LVRT Fault	Utility grid exception. The duration of the utility grid exception exceeds the set time of LVRT.	<ol style="list-style-type: none"> <li>If the problem occurs occasionally, the utility grid may be abnormal temporarily. The inverter will recover automatically after detecting that the utility grid is normal.</li> <li>If the problem occurs frequently, check whether the grid frequency is within the permissible range. If not, contact the local power company. If yes, contact the dealer or the after-sales service.</li> </ol>
37	ID-103	Heat-Sink 1 Over Temp.	<ol style="list-style-type: none"> <li>Inverter installation location is not well-ventilated</li> <li>Operation temperature exceeds Over 140°F (60°C)</li> <li>abnormal operation of the internal fan</li> </ol>	<ol style="list-style-type: none"> <li>Check whether the ventilation at the installation location of the inverter is good and whether the temperature exceeds the allowable temperature range.</li> <li>If yes, please improve ventilation and cooling conditions.</li> <li>If no, please contact your dealer or after-sales service center</li> </ol>
38	ID-104	Heat-Sink 2 Over Temp.	/	Restart the system, Contact the dealer or the after-sales service if the problem persists.
39	ID-107	AC Comm. Fault with PMU	<ol style="list-style-type: none"> <li>Frame format error</li> <li>Parity checking error</li> <li>Can bus offline</li> <li>Hardware CRC error</li> <li>Send (receive) control bit is received (sent).</li> <li>Transmit to the unit that is not allowed.</li> </ol>	<ol style="list-style-type: none"> <li>Disconnect the AC output switch and DC input switch, then connect them 5 minutes later.</li> <li>Contact the dealer or the after-sales service if the problem persists.</li> </ol>
40	ID-108	AC Comm. Fault with DC	/	Restart the system, Contact the dealer or the after-sales service if the problem persists.
41	ID-109	Heat-Sink OT Derating	/	Restart the system, Contact the dealer or the after-sales service if the problem persists.
42	ID-110	Grid Freq Derating	/	Restart the system, Contact the dealer or the after-sales service if the problem persists.
43	ID-112	High Gen. Freq	/	Restart the system, Contact the dealer or the after-sales service if the problem persists.
44	ID-113	Grid Volt Derating	/	Restart the system, Contact the dealer or the after-sales service if the problem persists.
45	ID-118	Pos Bus HW OV	/	Restart the system, Contact the dealer or the after-sales service if the problem persists.
46	ID-119	Neg Bus HW OV	/	Restart the system, Contact the dealer or the after-sales service if the problem persists.

47	ID-120	Inv HW Short	/	Restart the system, Contact the dealer or the after-sales service if the problem persists.
48	ID-130	CT Fault	/	Restart the system, Contact the dealer or the after-sales service if the problem persists.
49	ID-132	AC MCU Fault	/	Restart the system, Contact the dealer or the after-sales service if the problem persists.
50	ID-134	Bus soft start timeout	/	Restart the system, Contact the dealer or the after-sales service if the problem persists.
51	ID-135	Inverter soft start timeout	/	Restart the system, Contact the dealer or the after-sales service if the problem persists.
52	ID-136	Grounding Fault	<ol style="list-style-type: none"> <li>The PE cable of the inverter is not connected well.</li> <li>The L cable and N cable are connected reversely when output of the PV string is grounded.</li> </ol>	<ol style="list-style-type: none"> <li>Check whether the PE cable of the inverter is connected properly.</li> <li>Check whether the L cable and N cable are connected reversely if output of the PV string is grounded.</li> </ol>
53	ID-153	Load Volt OV	/	Restart the system, Contact the dealer or the after-sales service if the problem persists.
54	ID-154	Load Curr SC	/	Restart the system, Contact the dealer or the after-sales service if the problem persists.
55	ID-155	Meter Comm. Fault	/	Restart the system, Contact the dealer or the after-sales service if the problem persists.
56	ID-157	Inv Curr Peak OC	/	Restart the system, Contact the dealer or the after-sales service if the problem persists.
57	ID-173	Parallel Parameter Set Err	/	Restart the system, Contact the dealer or the after-sales service if the problem persists.
58	ID-174	Master Set Err	/	Restart the system, Contact the dealer or the after-sales service if the problem persists.
59	ID-175	Slaver Addr Set Err	/	Restart the system, Contact the dealer or the after-sales service if the problem persists.
60	ID-176	Slave address setting error	/	Restart the system, Contact the dealer or the after-sales service if the problem persists.
61	ID-177	High Grid Freq Class 2	/	Restart the system, Contact the dealer or the after-sales service if the problem persists.
62	ID-178	Low Grid Freq Class 2	/	Restart the system, Contact the dealer or the after-sales service if the problem persists.
63	ID-197	L1 Grid Volt RMS OV Class 2	The grid voltage is abnormal or ultra-high.	<ol style="list-style-type: none"> <li>If the problem occurs occasionally, the utility grid may be abnormal temporarily. The inverter will recover automatically after detecting that the utility grid is normal.</li> <li>If the problem occurs frequently, check whether the grid voltage is within the permissible range. <ul style="list-style-type: none"> <li>Contact the local power company if the grid voltage exceeds the permissible range.</li> <li>Modify the grid overvoltage rapid protection threshold after obtaining the consent of the local power company if the grid voltage is within the permissible range.</li> </ul> </li> </ol>
64	ID-180	L2 Grid Volt RMS OV Class 2	/	Restart the system, Contact the dealer or the after-sales service if the problem persists.
65	ID-182	L1 Grid Volt RMS UV Class 2	/	Restart the system, Contact the dealer or the after-sales service if the problem persists.
66	ID-183	L2 Grid Volt RMS UV Class 2	/	Restart the system, Contact the dealer or the after-sales service if the problem persists.
67	ID-185	L1 and L2 Phase Fault	/	Restart the system, Contact the dealer or the after-sales service if the problem persists.
68	ID-186	Parallel Master Lost	/	Restart the system, Contact the dealer or the after-sales service if the problem persists.

69	ID-187	Industrial Freq. Lost	/	Restart the system, Contact the dealer or the after-sales service if the problem persists.
70	ID-188	High Freq. Lost	/	Restart the system, Contact the dealer or the after-sales service if the problem persists.
71	ID-189	Parallel Comm. Err	/	Restart the system, Contact the dealer or the after-sales service if the problem persists.
72	ID-190	Neg Power OP Lv1	/	Restart the system, Contact the dealer or the after-sales service if the problem persists.
73	ID-191	Neg Power OP Lv2	/	Restart the system, Contact the dealer or the after-sales service if the problem persists.
74	ID-199	Pos Bus Volt Peak OV(Break)	/	Restart the system, Contact the dealer or the after-sales service if the problem persists.
75	ID-200	Neg Bus Volt Peak OV(Break)	/	Restart the system, Contact the dealer or the after-sales service if the problem persists.
76	ID-201	Pos Bus Volt RMS OV	/	Restart the system, Contact the dealer or the after-sales service if the problem persists.
77	ID-202	Neg Bus Volt RMS OV	/	Restart the system, Contact the dealer or the after-sales service if the problem persists.
78	ID-203	Pos Bus Volt RMS UV	/	Restart the system, Contact the dealer or the after-sales service if the problem persists.
79	ID-204	Neg Bus Volt RMS UV	/	Restart the system, Contact the dealer or the after-sales service if the problem persists.
80	ID-205	Pos Bus Volt HW OV	/	Restart the system, Contact the dealer or the after-sales service if the problem persists.
81	ID-206	Neg Bus Volt HW OV	/	Restart the system, Contact the dealer or the after-sales service if the problem persists.
82	ID-209	Buck-Boost 1 SW OC	/	Restart the system, Contact the dealer or the after-sales service if the problem persists.
83	ID-210	Buck-Boost 2 SW OC	/	Restart the system, Contact the dealer or the after-sales service if the problem persists.
84	ID-211	Buck-Boost 3 SW OC	/	Restart the system, Contact the dealer or the after-sales service if the problem persists.
85	ID-216	Bus OC Protect	<ol style="list-style-type: none"> <li>The DC terminal is not firmly connected.</li> <li>The DC cable is broken.</li> </ol>	Check whether the cables are connected properly in accordance with the requirements.
86	ID-217	DC Comm. Fault with PMU	/	Restart the system, Contact the dealer or the after-sales service if the problem persists.
87	ID-218	DC Comm. Fault with AC	/	Restart the system, Contact the dealer or the after-sales service if the problem persists.
88	ID-219	BMS Comm. Fault	/	Restart the system, Contact the dealer or the after-sales service if the problem persists.
89	ID-221	DC Heat-Sink 1 Over Temp.	<ol style="list-style-type: none"> <li>Inverter installation location is not well-ventilated</li> <li>Operation temperature exceeds Over 140°F (60°C)</li> <li>abnormal operation of the internal fan</li> </ol>	<ol style="list-style-type: none"> <li>Check whether the ventilation at the installation location of the inverter is good and whether the temperature exceeds the allowable temperature range.</li> <li>If yes, please improve ventilation and cooling conditions.</li> <li>If no, please contact your dealer or after-sales service center</li> </ol>
90	ID-222	DC Heat-Sink 2 Over Temp.	/	Restart the system, Contact the dealer or the after-sales service if the problem persists.
91	ID-261	DC MCU Fault	/	Restart the system, Contact the dealer or the after-sales service if the problem persists.
92	ID-262	EPO Break	/	Restart the system, Contact the dealer or the after-sales service if the problem persists.
93	ID-289	PVI Insulation Fault	<ol style="list-style-type: none"> <li>The PV string is short-circuited to PE.</li> <li>The PV system is in a</li> </ol>	<ol style="list-style-type: none"> <li>Check whether the resistance of the PV string to PE exceeds 50kΩ. If no, check the short circuit point.</li> </ol>

			moist environment and the cable is not well insulated to the ground	<p>2. Check whether the PE cable is connected correctly.</p> <p>3. If the resistance is lower on rainy days, please reset the insulation resistance protection threshold</p>
94	ID-290	PV2 Insulation Fault	/	Restart the system, Contact the dealer or the after-sales service if the problem persists.
95	ID-291	PV3 Insulation Fault	/	Restart the system, Contact the dealer or the after-sales service if the problem persists.
96	ID-292	PV4 Insulation Fault	/	Restart the system, Contact the dealer or the after-sales service if the problem persists.
97	ID-305	PV1 Volt OV	The PV array configuration is not correct. Too many PV panels are connected in series in the PV string.	Check the serial connection of the PV array. Make sure that the open circuit voltage of the PV string is not higher than the maximum operating voltage of the inverter.
98	ID-306	PV2 Volt OV	/	Restart the system, Contact the dealer or the after-sales service if the problem persists.
99	ID-307	PV3 Volt OV	/	Restart the system, Contact the dealer or the after-sales service if the problem persists.
100	ID-308	PV4 Volt OV	/	Restart the system, Contact the dealer or the after-sales service if the problem persists.
101	ID-313	PV1 Curr OC	<p>1. The PV configuration is not proper.</p> <p>2. The hardware is damaged.</p>	<p>Disconnect the AC output switch and DC input switch, then connect them 5 minutes later.</p> <p>Contact the dealer or the after-sales service if the problem persists.</p>
102	ID-314	PV2 Curr OC	/	Restart the system, Contact the dealer or the after-sales service if the problem persists.
103	ID-315	PV3 Curr OC	/	Restart the system, Contact the dealer or the after-sales service if the problem persists.
104	ID-316	PV4 Curr OC	/	Restart the system, Contact the dealer or the after-sales service if the problem persists.
105	ID-323	Arc Fault	/	Restart the system, Contact the dealer or the after-sales service if the problem persists.
106	ID-324	AFCI Self-Check Fault	/	Restart the system, Contact the dealer or the after-sales service if the problem persists.
107	ID-325	AFCI Comm. Fault	/	Restart the system, Contact the dealer or the after-sales service if the problem persists.
108	ID-355~ID-362	Battery Fault	/	<p>1. Disconnect the AC output switch and DC input switch, take off the battery, then connect them 5 minutes later.</p> <p>2. Contact the dealer or the after-sales service if the problem persists.</p>
109	ID-369	Charge Over-voltage 2	/	Restart the system, Contact the dealer or the after-sales service if the problem persists.
110	ID-370	Discharge Under-voltage 2	/	Restart the system, Contact the dealer or the after-sales service if the problem persists.
111	ID-371	Cell High Temp.2	/	Restart the system, Contact the dealer or the after-sales service if the problem persists.
112	ID-372	Cell Low Temp. 2	/	Restart the system, Contact the dealer or the after-sales service if the problem persists.
113	ID-373	Charge Over-current 2	/	Restart the system, Contact the dealer or the after-sales service if the problem persists.
114	ID-374	Discharge Over-current 2	/	Restart the system, Contact the dealer or the after-sales service if the problem persists.
115	ID-379	Discharge Loop failure	/	Restart the system, Contact the dealer or the after-sales service if the problem persists.
116	ID-380	Charge Loop failure	/	Restart the system, Contact the dealer or the after-sales service if the problem persists.
117	ID-382	Cell High temp. 3	/	Restart the system, Contact the dealer or the after-sales service if the problem persists.

118	ID-383	Discharge Under-voltage 3	/	Restart the system, Contact the dealer or the after-sales service if the problem persists.
119	ID-384	Charge Over-voltage 3	/	Restart the system, Contact the dealer or the after-sales service if the problem persists.
120	ID-385	Charge Over temp. 2	/	Restart the system, Contact the dealer or the after-sales service if the problem persists.
121	ID-386	Charge Low temp. 2	/	Restart the system, Contact the dealer or the after-sales service if the problem persists.
122	ID-387	Discharge Over temp. 2	/	Restart the system, Contact the dealer or the after-sales service if the problem persists.
123	ID-388	Discharge Low temp. 2	/	Restart the system, Contact the dealer or the after-sales service if the problem persists.
124	ID-389	Cell temp. diff over range 2	/	Restart the system, Contact the dealer or the after-sales service if the problem persists.
125	ID-390	Cell Over Voltage 2	/	Restart the system, Contact the dealer or the after-sales service if the problem persists.
126	ID-391	Cell under Voltage 2	/	Restart the system, Contact the dealer or the after-sales service if the problem persists.
127	ID-392	Cell voltage difference over range 2	/	Restart the system, Contact the dealer or the after-sales service if the problem persists.
128	ID-393	Over-power charge	/	Restart the system, Contact the dealer or the after-sales service if the problem persists.
129	ID-394	Over-power discharge	/	Restart the system, Contact the dealer or the after-sales service if the problem persists.
130	ID-401	Charge voltage high 1 Pack voltage high 1	/	Restart the system, Contact the dealer or the after-sales service if the problem persists.
131	ID-402	Discharge voltage low 1 Pack voltage low 1	/	Restart the system, Contact the dealer or the after-sales service if the problem persists.
132	ID-403	Cell temperature high 1	/	Restart the system, Contact the dealer or the after-sales service if the problem persists.
133	ID-404	Cell temperature low 1	/	Restart the system, Contact the dealer or the after-sales service if the problem persists.
134	ID-409	Pack voltage difference 1	/	Restart the system, Contact the dealer or the after-sales service if the problem persists.
135	ID-410	System temperature low 1	/	Restart the system, Contact the dealer or the after-sales service if the problem persists.
136	ID-412	System temperature high	/	Restart the system, Contact the dealer or the after-sales service if the problem persists.
137	ID-415	Pack temperature difference 1	/	Restart the system, Contact the dealer or the after-sales service if the problem persists.
138	ID-416	Charge temperature high 1	/	Restart the system, Contact the dealer or the after-sales service if the problem persists.
139	ID-417	Charge temperature low 1	/	Restart the system, Contact the dealer or the after-sales service if the problem persists.
140	ID-418	Discharge temperature high 1	/	Restart the system, Contact the dealer or the after-sales service if the problem persists.
141	ID-419	Discharge temperature low 1	/	Restart the system, Contact the dealer or the after-sales service if the problem persists.
142	ID-420	Charge over current 1 Charge power over limit	/	Restart the system, Contact the dealer or the after-sales service if the problem persists.
143	ID-421	Discharge over current 1 Discharge power under limit	/	Restart the system, Contact the dealer or the after-sales service if the problem persists.
144	ID-422	SOC over limit	/	Restart the system, Contact the dealer or the after-sales service if the problem persists.
145	ID-423	SOC under limit	/	Restart the system, Contact the dealer or the after-sales service if the problem persists.
146	ID-435	Battery Fault	/	1. Disconnect the AC output switch and DC input

14 7	ID-456~ ID-460	Battery Fault	/	switch, take off the battery, then connect them 5 minutes later. 2. Contact the dealer or the after-sales service if the problem persists.
14 8	ID-369~ ID-434	Battery Alarm	/	
14 9	ID-436~ ID-354			
150	ID-461~ ID-525			





## 10. Technical specifications

### Inverter

Model	SUN1000S-U	SUN1200S-U	SUN1500S-U
<b>PV input</b>			
V <sub>max</sub> PV (Vdc)	550V	550V	550V
I <sub>sc</sub> PV	20A	40A	40A
Maximum operating PV input current (each MPPT)	15.5A	27A	27A
Maximum operating PV input current (each String)	15.5A	18A	18A
Nominal input voltage (dc)	384V	384V	384V
Range of PV input operating voltage (Vdc)	120-550V	120-550V	120-550V
Range of PV voltage@ full output (Vdc)	235-550V	200-550V	225-550V
Start input voltage (Vdc)	150V	150V	150V
No. of MPPT/Strings per MPPT	4/1	4/2	4/2
Max input power per MPPT (W)	3.6KW	5KW	6KW
Max. PV input power	14.4KW	20KW	24KW
<b>Grid terminal parameters</b>			
Nominal AC output voltage (Vac)	120/240V (L1, L2, N)	120/240 V (L1, L2, N)	120/240V (L1, L2, N)
Nominal AC output frequency (Hz)	60Hz	60Hz	60Hz
Nominal AC output current (Aac)	41.6A	50A	62.5A
Nominal AC output power (W)(240V)	10KW	12KW	15KW
Max. Continuous AC output current (Aac)	41.6A	50A	62.5A
Max. Continuous AC output power (VA)	10KVA	12KVA	15KVA
Output power factor rating	0.8leading...0.8lagging		
Nominal AC input voltage (Vac)	240V	240V	240V
Nominal AC input frequency (Hz)	60Hz	60Hz	60Hz
Max. Continuous AC input current (Aac)	83.3A	83.3A	83.3A
Nominal AC input power (W)	20KW	20KW	20KW
Max. Continuous AC input power (VA)	20KVA	20KVA	20KVA
Nominal AC input current, Grid Charge to battery (Aac),(W)	41.6A	50A	62.5A
Max. Continuous AC input current, Grid Charge to battery (Aac)	41.6A	50A	62.5A
Nominal AC input power, Grid Charge to battery (W)	10KW	12KW	15KW
Max. Continuous AC input power, Grid Charge to battery (VA)	10KVA	12KVA	15KVA
Max output overcurrent protection (amps)	110A 3P	110A 3P	110A 3P

Back-up terminal parameters			
Nominal AC output voltage (Vac)	120/240V (L1, L2, N)	120/240V (L1, L2, N)	120/240V (L1, L2, N)
Nominal AC output frequency (Hz)	60Hz	60Hz	60Hz
Nominal AC output power (W)	19KW	19KW	19KW
Max. Continuous AC output current (Aac)	79.2A	79.2A	79.2A
Max. Continuous AC output power (VA)	19KVA	19KVA	19KVA
Generator terminal parameters			
Nominal AC input voltage (Vac)	120/240V (L1, L2)	120/240V (L1, L2)	120/240V (L1, L2)
Nominal AC input frequency (Hz)	60Hz	60Hz	60Hz
Nominal AC input current (Aac)	79.2A	79.2A	79.2A
Max.Continuous AC input current (Aac)	79.2A	79.2A	79.2A
Nominal AC input power (W)	19KW	19KW	19KW
Max.Continuous AC input power (VA)	19KVA	19KVA	19KVA
Battery terminal parameters			
Battery Type	LFP	LFP	LFP
Nominal voltage (Vdc)	153.6V	204.8V	204.8V
Range of DC discharging/input voltage (Vdc)	75-480V	75-480V	75-480V
Max. charging/output current (Adc)	75A	75A	75A
Max. charging power/output (W)	10KW	12KW	15KW
Other parameters			
Storage temperature	-22°F(-30°)~ 140°F (60°)	-22°F(-30°)~ 140°F (60°)	-22°F(-30°)~ 140°F (60°)
Storage humidity	0~95%	0~95%	0~95%
Normal operation temperature range	-22°F(-30°)~ 140°F (60°)	-22°F(-30°)~ 140°F (60°)	-22°F(-30°)~ 140°F (60°)
Output power temperature derating	113°F(45°)	113°F(45°)	113°F(45°)
Enclosure Type	Type 4X	Type 4X	Type 4X
Certificate	UL1741:3RD , CSA-C22.2 NO.107.1, UL1998,UL1699B ,IEEE1547-2018, IEEE1547.1-2020 , IEEE2030.5(2018&IEEE1547.1-2020)CEC-300-2018-009-CMF,FCC PART15B:2020 , ICES-003 ISSUE 7		

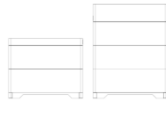
## Battery

Model	2*RBmax5.1 H	3*RBmax5.1 H	4*RBmax5.1 H	5*RBmax5.1H	6*RBmax5.1 H	7*RBmax5.1 H	8*RBmax5.1H
							
Electric Data							
Nominal Energy (kWh)	10.24kWh	15.36kWh	20.48kWh	25.6kWh	30.72kWh	35.84kWh	40.96kWh
Usable Energy (kWh)	9.58kWh	14.37kWh	19.16kWh	23.95kWh	28.74kWh	33.53kWh	38.32kWh
Cell Type	LFP (LiFePO <sub>4</sub> )	LFP (LiFePO <sub>4</sub> )	LFP (LiFePO <sub>4</sub> )	LFP (LiFePO <sub>4</sub> )	LFP (LiFePO <sub>4</sub> )	LFP (LiFePO <sub>4</sub> )	LFP (LiFePO <sub>4</sub> )

Nominal Voltage (V)	102.4	153.6	204.8	256	307.2	358.4	409.6
Operating Voltage Range (V)	89.6~113.6	134.4~170.4	179.2~227.2	224~284	268.8~340.8	313.6~397.6	358.4~454.4
Max. Continuous charge Current (A)	50	50	50	50	50	50	50
Max. Continuous Discharge Current (A)	75	75	75	75	75	75	75
<b>General Data</b>							
Weight (Kg)	106	153	200	251	298	345	392
Dimensions (W × D × H) (mm)	845×200×80 5	845×200×107 5	845×200×134 5	845×200×685 , 845×200×107 5	845×200×955 , 845×200×107 5	845×200×955 , 845×200×134 5	845×200×1225 , 845×200×134 5
Operating Temperature (°C)	Charge: 32°F~131°F (0~55°C);  Discharge: -4°F~131°F (-20~55°C)	Charge: 32°F~131°F (0~55°C);  Discharge: -4°F~131°F (-20~55°C)	Charge: 32°F~131°F (0~55°C);  Discharge: -4°F~131°F (-20~55°C)	Charge: 32°F~131°F (0~55°C);  Discharge: -4°F~131°F (-20~55°C)	Charge: 32°F~131°F (0~55°C);  Discharge: -4°F~131°F (-20~55°C)	Charge: 32°F~131°F (0~55°C);  Discharge: -4°F~131°F (-20~55°C)	Charge: 32°F~131°F (0~55°C);  Discharge: -4°F~131°F (-20~55°C)
Storage temperature (°C) Delivery SOC State (20~40%)	>1 month: 32°F~95°F (0~35°C)	>1 month: 32°F~95°F (0~35°C)	>1 month: 32°F~95°F (0~35°C)	>1 month: 32°F~95°F (0~35°C)	>1 month: 32°F~95°F (0~35°C)	>1 month: 32°F~95°F (0~35°C)	>1 month: 32°F~95°F (0~35°C)
	≤1 month: -4°F~113°F (-20~45°C)	≤1 month: -4°F~113°F (-20~45°C)	≤1 month: -4°F~113°F (-20~45°C)	≤1 month: -4°F~113°F (-20~45°C)	≤1 month: -4°F~113°F (-20~45°C)	≤1 month: -4°F~113°F (-20~45°C)	≤1 month: -4°F~113°F (-20~45°C)
Relative Humidity	≤ 95%	≤ 95%	≤ 95%	≤ 95%	≤ 95%	≤ 95%	≤ 95%
Max. Altitude (m)	4000 (>2000m de-rating)	4000 (>2000m de-rating)	4000 (>2000m de-rating)	4000 (>2000m de-rating)	4000 (>2000m de-rating)	4000 (>2000m de-rating)	4000 (>2000m de-rating)
Protection Degree	IP 65	IP 65	IP 65	IP 65	IP 65	IP 65	IP 65
Installation Location	Ground-Mounted Wall-Mounted	Ground-Mounted Wall-Mounted	Ground-Mounted Wall-Mounted	Ground-Mounted Wall-Mounted	Ground-Mounted Wall-Mounted	Ground-Mounted Wall-Mounted	Ground-Mounted Wall-Mounted
Communication	CAN, RS485	CAN, RS485	CAN, RS485	CAN, RS485	CAN, RS485	CAN, RS485	CAN, RS485
<b>Certification</b>							
Safety	UL9540, UL9540A, UL1973	UL9540, UL9540A, UL1973	UL9540, UL9540A, UL1973	UL9540, UL9540A, UL1973	UL9540, UL9540A, UL1973	UL9540, UL9540A, UL1973	UL9540, UL9540A, UL1973
FCC	FCC PART 15 B	FCC PART 15 B	FCC PART 15 B	FCC PART 15 B	FCC PART 15 B	FCC PART 15 B	FCC PART 15B
Transportation	UN38.3	UN38.3	UN38.3	UN38.3	UN38.3	UN38.3	UN38.3
<b>Warranty (Years)</b>	5/10(Optional)	5/10(Optional)	5/10(Optional)	5/10(Optional)	5/10(Optional)	5/10(Optional)	5/10(Optional)

# THANKS!

HuiZhou RoyPow Technology Co.,Ltd.

Email:

[sales@roypow.com](mailto:sales@roypow.com)

[service@roypow.com](mailto:service@roypow.com)

[marketing@roypow.com](mailto:marketing@roypow.com)

Web: [www.roypow.com](http://www.roypow.com)

Tel: +86 (0) 752 327 9099

Add: ROYPOW Industrial Park, No. 16, Dongsheng South Road, Chenjiang Street, Zhongkai High-Tech District, Huizhou City, Guangdong Province, china